



Steering Columns System

Thermoformed plastic covers

EU SAFETY & QUALITY STANDARD
CUSTOMIZED ASSEMBLY
ITALIAN DESIGN
OPERATOR COMFORT

ama

IMEL Division



CL170
Short
pag. 4



CL180
pag. 5



CL500
pag. 6



CL810
pag. 7



CL810
Short
pag. 8



CL820
pag. 9



CL820
Short
pag. 10



CL830
pag. 11



CL830
Short
pag. 12



CL850
pag. 13



CL850
Short
pag. 14



CL870
pag. 15



CL900
pag. 16



CL900
Short
pag. 17



CL950
short
pag. 18



CL2000
pag. 19



CL2000
short
pag. 20



CL2200
pag. 21



CL2300
pag. 22



CL2302
pag. 23



SERIE 6
pag. 26



SERIE 9
pag. 26



SERIE 10
pag. 27



SERIE 11
pag. 27



SERIE 12
pag. 28



SERIE 18
pag. 28



Knob
pag. 29



J-Cluster
pag. 29



NIMBUS
pag. 29



D100TFT
pag. 29



SMARTVIEW
pag. 29

CL170 Short

BCH

metal pillar



tilt



CARATTERISTICHE STANDARD

Colonna guida regolabile completa di piantone con attacco per idroguida

Regolazione dell'inclinazione di 20° in direzione del conducente e di 5° sul lato opposto mediante leva.

Rivestimento in materiale plastico ABS nero/grigio.

Strumentazione e apparecchiature di comando componibili secondo l'esigenza del cliente

Completa di cablaggio

Colorazione standard: nero

Si eseguono colorazioni speciali su richiesta

STANDARD FEATURES

Adjustable steering column with connection for hydraulic power steering

Tilt adjustment of 20° toward the operator and 5° toward windshield by level

Black/grey ABS plastic covers

Instrumentation and electric components per customer requisit

Complete with wiring loom

Standard colour: black

Different colours on demand

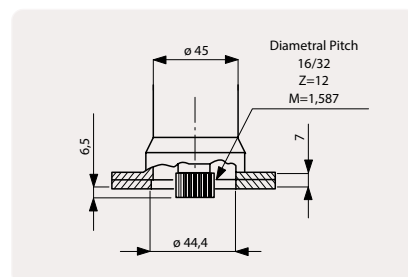
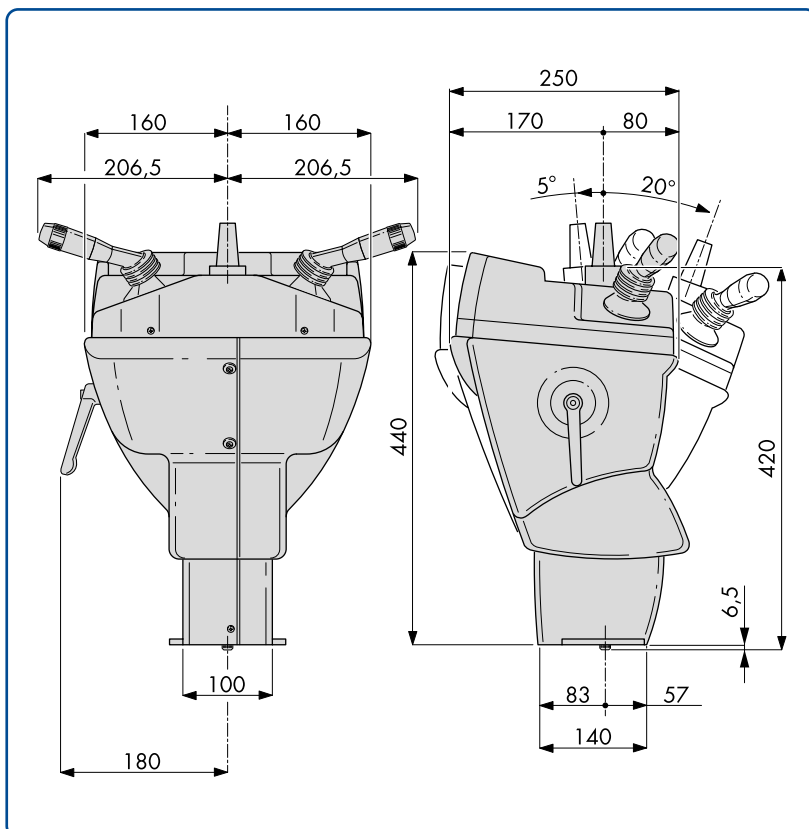

**Attacco standard idroguida
Standard hydraulic steering joint**

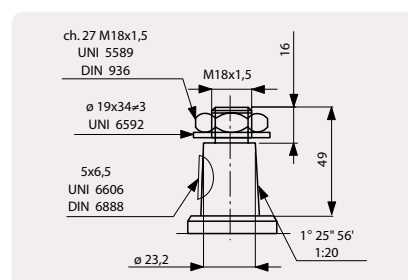

**Cono fissaggio volante
Standard cone**

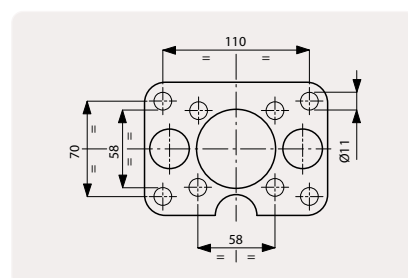

**Modello standard
Standard flanges**

CL180

BCH

metal pillar



tilt



CARATTERISTICHE STANDARD

Colonna guida regolabile completa di piantone con attacco per idroguida

Regolazione dell'inclinazione di 20° in direzione del conducente e di 5° sul lato opposto mediante leva

Rivestimento in materiale plastico ABS nero/grigio

Strumentazione e apparecchiature di comando componibili secondo l'esigenza del cliente.

Completa di cablaggio.

Colorazione standard: nero.

Si eseguono colorazioni speciali su richiesta.

STANDARD FEATURES

Adjustable steering column with connection for hydraulic power steering.

Tilt adjustment of 20° toward the operator and 5° toward windshield by level.

Black/grey ABS plastic covers.

Instrumentation and electric components per customer requisit.

Complete with wiring loom.

Standard colour: black.

Different colours on demand.

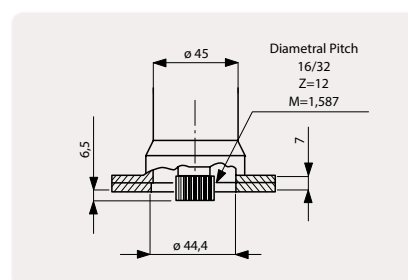
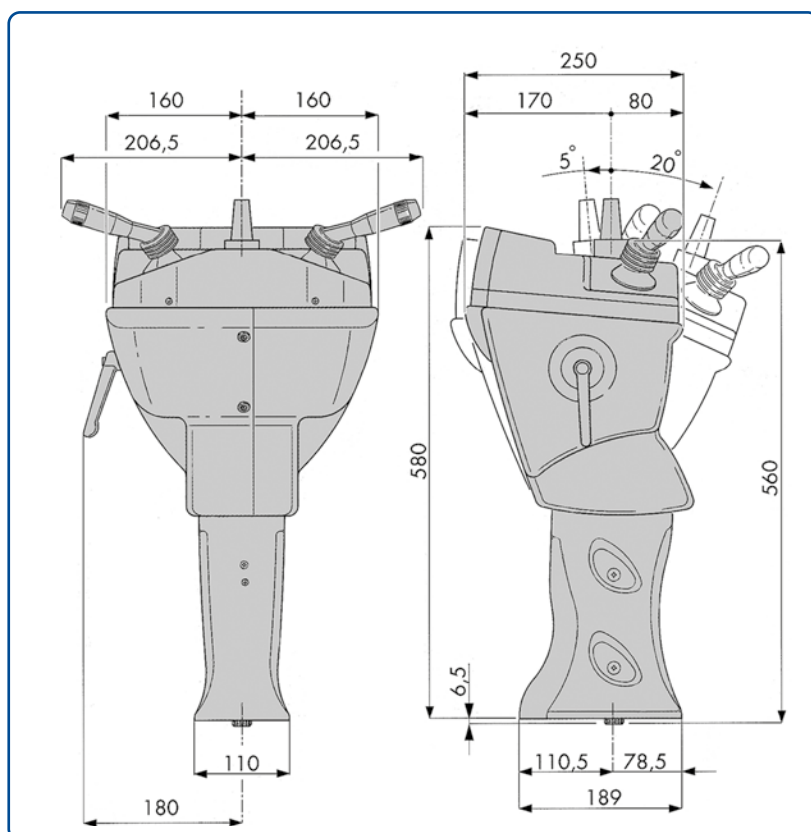

Attacco standard idroguida
Standard hydraulic steering joint

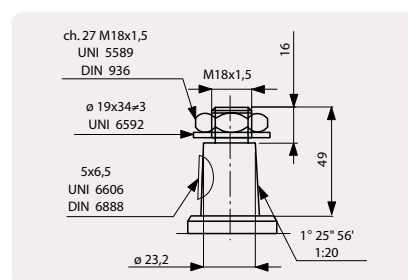

Cono fissaggio volante
Standard cone

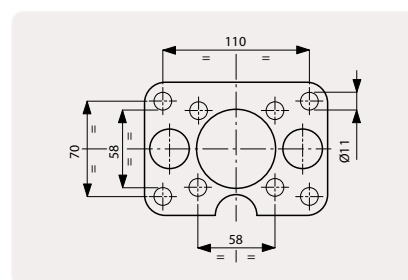

Modello standard
Standard flanges

CL500

BCH

metal pillar



tilt



60 mm



CARATTERISTICHE STANDARD

Colonna guida regolabile completa di piantone con attacco per idroguida.

Regolazione dell'inclinazione di 18° in direzione del conducente e di 6° sul lato opposto mediante leva.

Regolazione telescopica di 60 mm mediante leva.

Rivestimento in materiale plastico ABS nero/grigio.

Strumentazione e apparecchiature di comando componibili secondo l'esigenza del cliente.

Completa di cablaggio.

Si eseguono colorazioni speciali su richiesta.

STANDARD FEATURES

Adjustable steering column with connection for hydraulic power steering.

Tilt adjustment of 18° toward the operator and 6° toward windshield by lever.

Telescopic height adjustment of 60 mm by lever.

Black/grey ABS plastic covers.

Instrumentation and electric components on customer request.

Complete with wiring loom.

Different colours on demand.

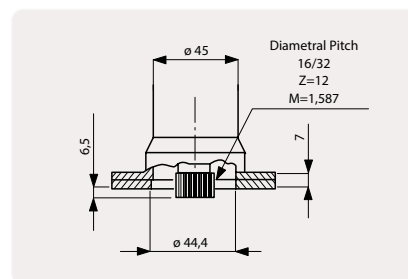
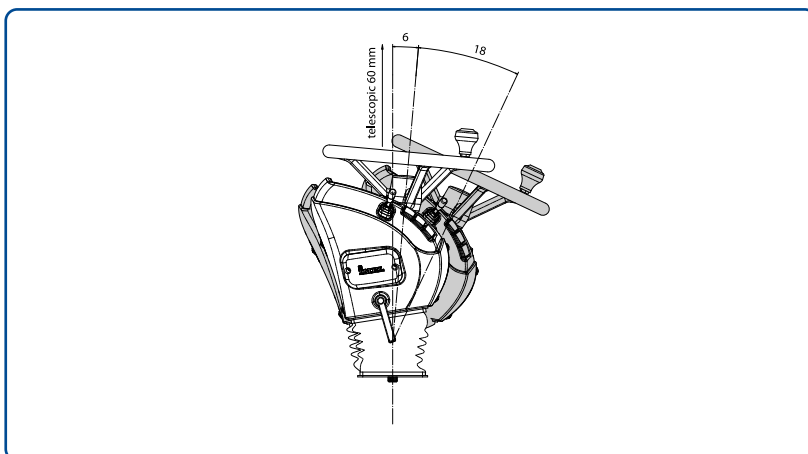

Attacco standard idroguida
Standard hydraulic steering joint

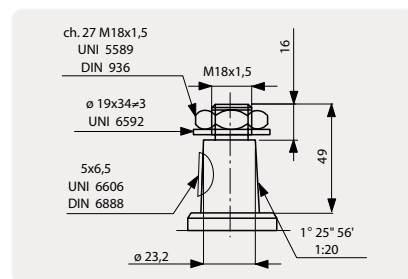
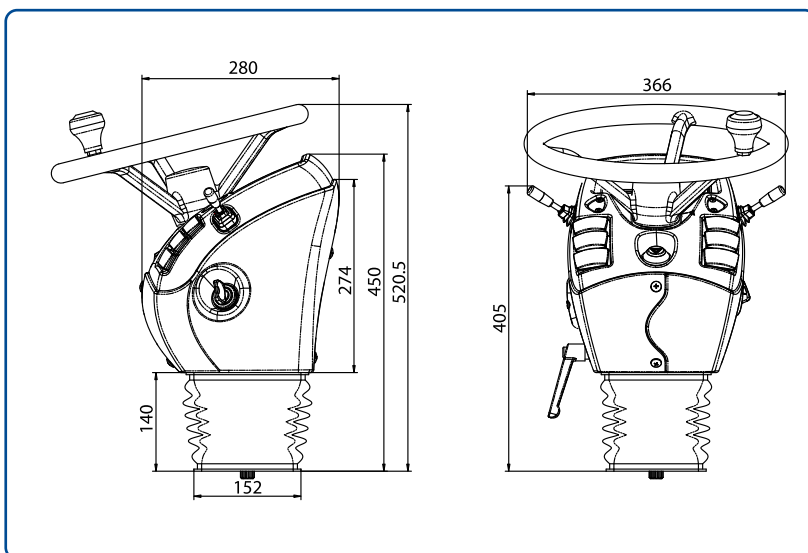

Cono fissaggio volante
Standard cone

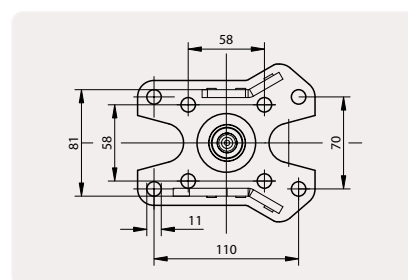

Modello standard
Standard flanges

CL810

BCH



metal pillar

tilt

60 mm



CARATTERISTICHE STANDARD

Colonna guida regolabile completa di piantone con attacco per idroguida.

Regolazione dell'inclinazione di 20° in direzione del conducente e di 5° sul lato opposto mediante leva.

Regolazione telescopica dell'altezza di 60 mm, mediante leva.

Rivestimento in materiale plastico ABS nero/grigio.

Strumentazione e apparecchiature di comando componibili secondo l'esigenza del cliente.

Completa di cablaggio.

Si eseguono colorazioni speciali su richiesta.

STANDARD FEATURES

Adjustable steering column with connection for hydraulic power steering.

Tilt adjustment of 20° toward the operator and 5° toward windshield by lever.

Telescopic height adjustment of 60 mm. by lever.

Black/grey ABS plastic covers.

Instrumentation and electric components per customer request.

Complete with wiring loom.

Different colours on demand.

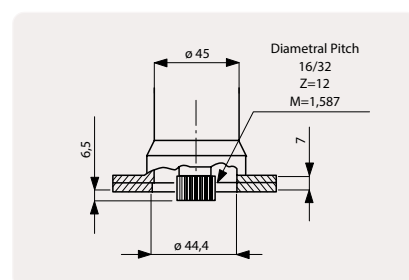
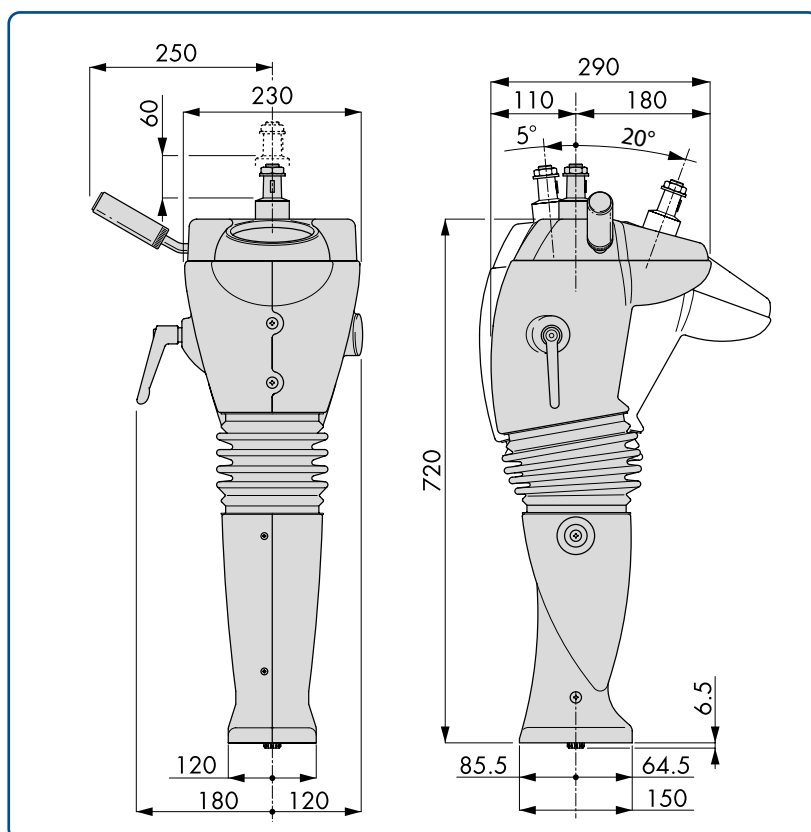

Attacco standard idroguida
Standard hydraulic steering joint

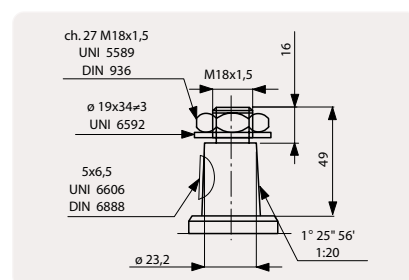

Cono fissaggio volante
Standard cone

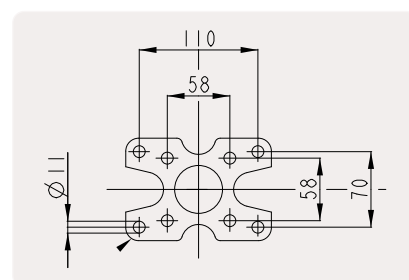

Modello standard
Standard flanges

CL810 short

BCH



metal pillar

tilt

60 mm



CARATTERISTICHE STANDARD

Colonna guida regolabile completa di piantone con attacco per idroguida.

Regolazione dell'inclinazione di 20° in direzione del conducente e di 5° sul lato opposto mediante leva.

Regolazione telescopica dell'altezza di 60 mm, mediante leva.

Rivestimento in materiale plastico ABS nero/grigio.

Strumentazione e apparecchiature di comando componibili secondo l'esigenza del cliente.

Completa di cablaggio.

Si eseguono colorazioni speciali su richiesta.

STANDARD FEATURES

Adjustable steering column with connection for hydraulic power steering.

Tilt adjustment of 20° toward the operator and 5° toward windshield by lever.

Telescopic height adjustment of 60 mm. by lever.

Black/grey ABS plastic covers.

Instrumentation and electric components per customer request.

Complete with wiring loom.

Different colours on demand.

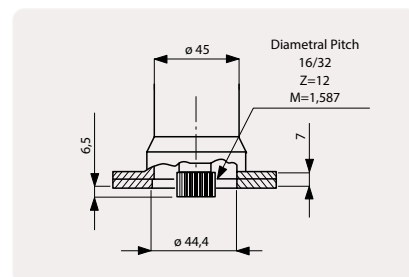
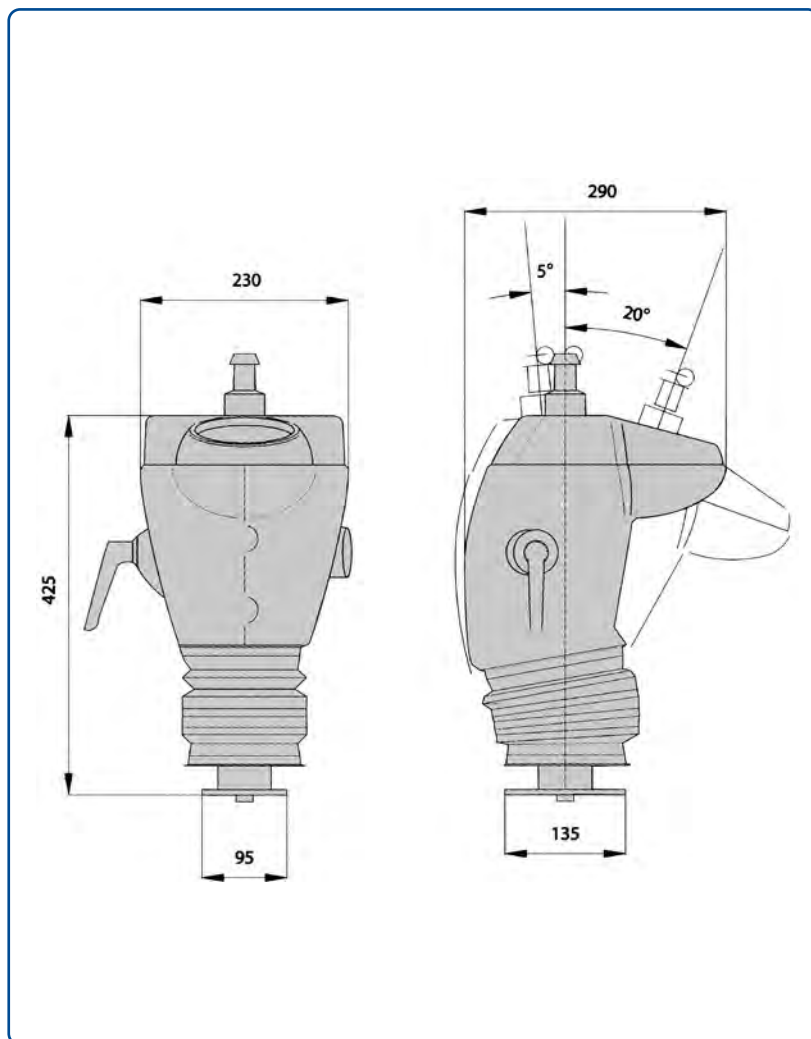

Attacco standard idroguida
Standard hydraulic steering joint

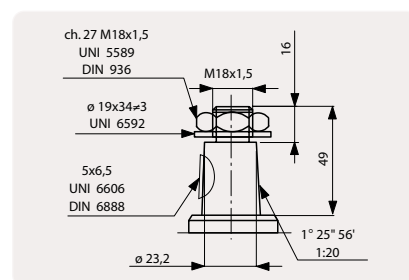

Cono fissaggio volante
Standard cone

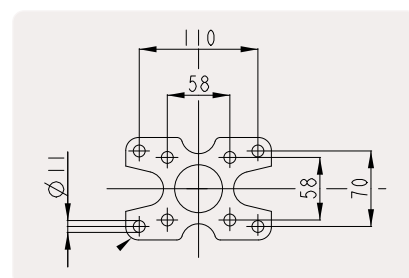

Modello standard
Standard flanges

CL820

BCH

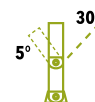

metal pillar

tilt

60 mm

CARATTERISTICHE STANDARD

Colonna guida regolabile completa di piantone con attacco per idroguida.

Regolazione dell'inclinazione di 20° in direzione del conducente e di 5° sul lato opposto mediante leva.

Regolazione telescopica dell'altezza di 60 mm, mediante leva.

Rivestimento in materiale plastico ABS nero/grigio.

Strumentazione e apparecchiature di comando componibili secondo l'esigenza del cliente.

Completa di cablaggio.

Si eseguono colorazioni speciali su richiesta.

STANDARD FEATURES

Adjustable steering column with connection for hydraulic power steering.

Tilt adjustment of 20° toward the operator and 5° toward windshield by lever.

Telescopic height adjustment of 60 mm. by lever.

Black/grey ABS plastic covers.

Instrumentation and electric components per customer request.

Complete with wiring loom.

Different colours on demand.

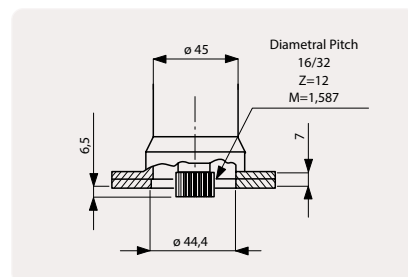
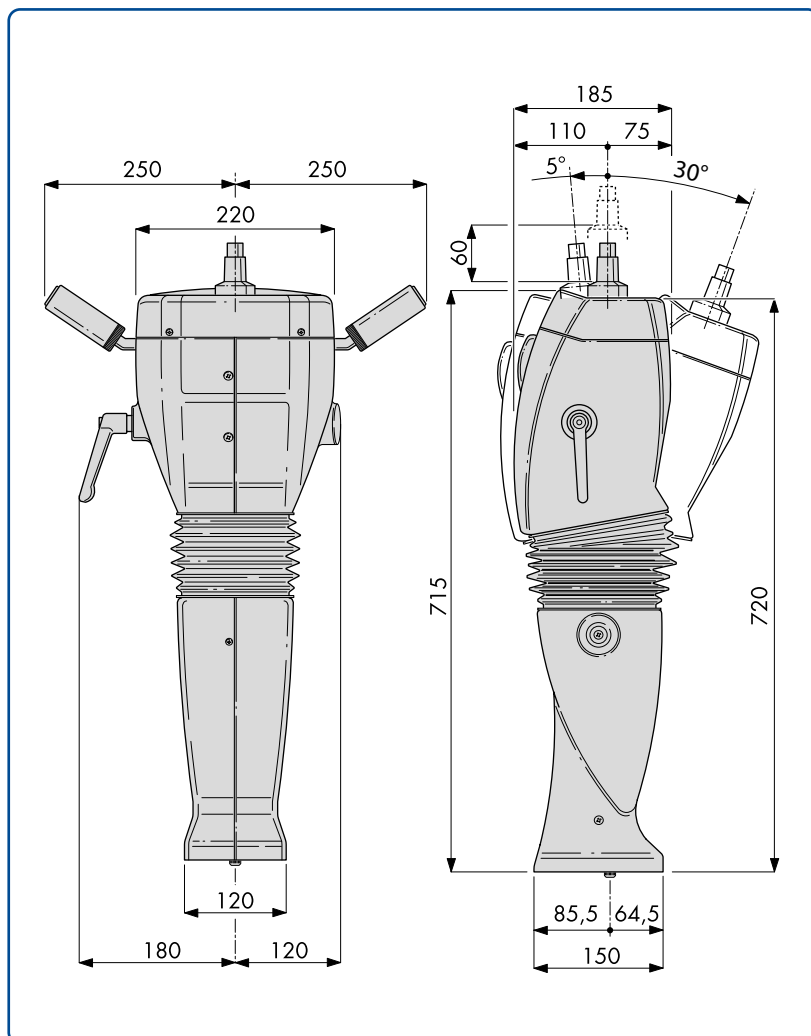

Attacco standard idroguida
Standard hydraulic steering joint

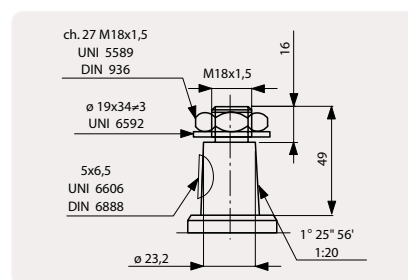

Cono fissaggio volante
Standard cone

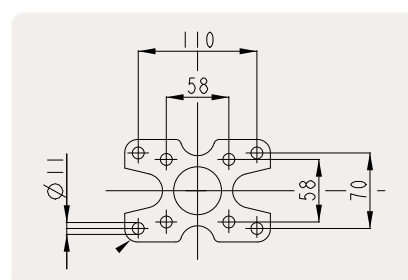

Modello standard
Standard flanges

CL820 short

BCH

metal pillar



tilt



60 mm



CARATTERISTICHE STANDARD

Colonna guida regolabile completa di piantone con attacco per idroguida.

Regolazione dell'inclinazione di 20° in direzione del conducente e di 5° sul lato opposto mediante leva.

Regolazione telescopica dell'altezza di 60 mm, mediante leva.

Rivestimento in materiale plastico ABS nero/grigio.

Strumentazione e apparecchiature di comando componibili secondo l'esigenza del cliente.

Completa di cablaggio.

Si eseguono colorazioni speciali su richiesta.

STANDARD FEATURES

Adjustable steering column with connection for hydraulic power steering.

Tilt adjustment of 20° toward the operator and 5° toward windshield by lever.

Telescopic height adjustment of 60 mm. by lever.

Black/grey ABS plastic covers.

Instrumentation and electric components per customer request.

Complete with wiring loom.

Different colours on demand.

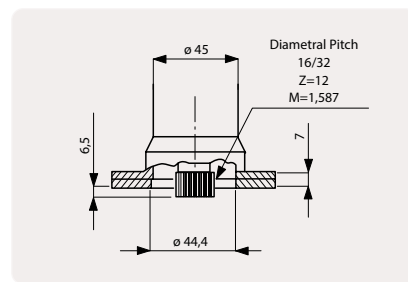
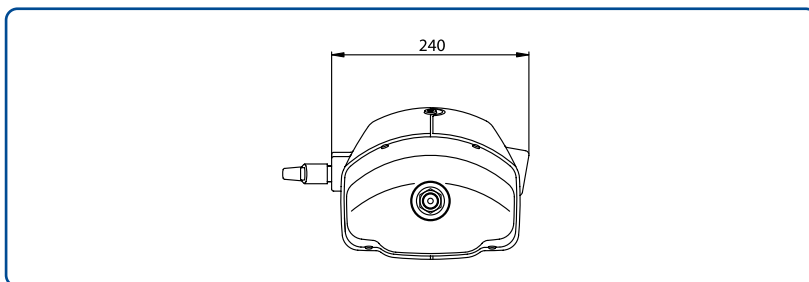

**Attacco standard idroguida
Standard hydraulic steering joint**

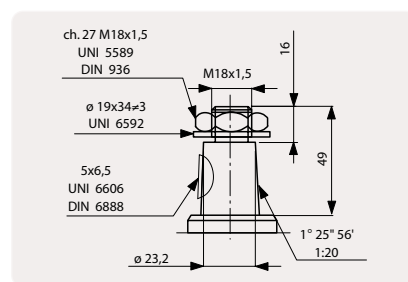
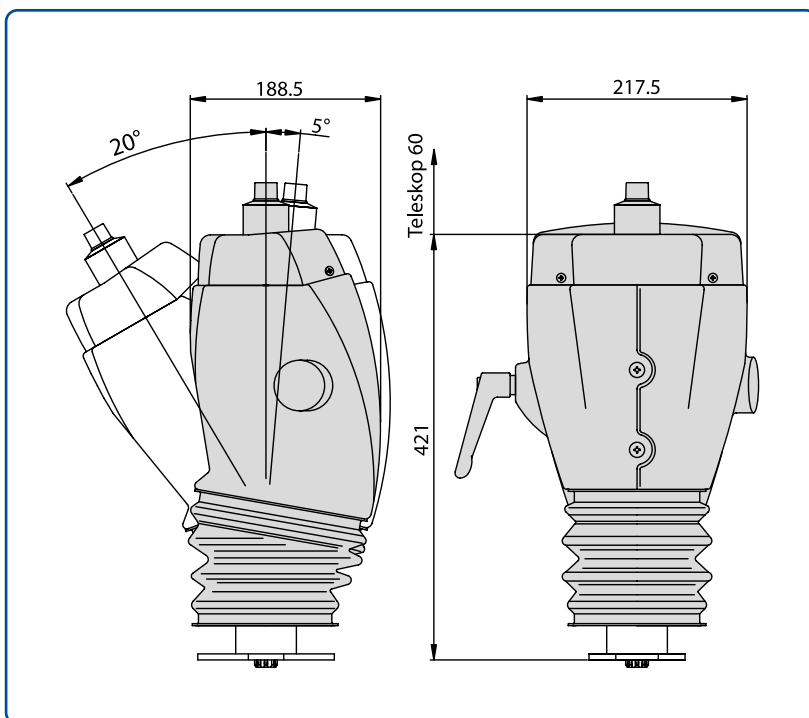

**Cono fissaggio volante
Standard cone**

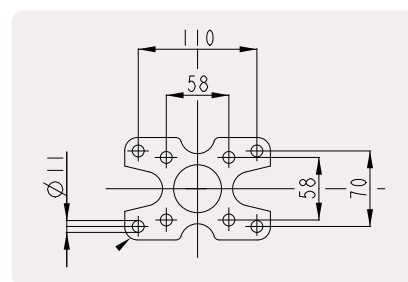

**Modello standard
Standard flanges**

CL830

BCH

metal pillar



tilt



60 mm



CARATTERISTICHE STANDARD

Colonna guida regolabile completa di piantone con attacco per idroguida.

Regolazione dell'inclinazione di 20° in direzione del conducente e di 5° sul lato opposto mediante leva.

Regolazione telescopica dell'altezza di 60 mm, mediante leva.

Rivestimento in materiale plastico ABS nero/grigio.

Strumentazione e apparecchiature di comando componibili secondo l'esigenza del cliente.

Completa di cablaggio.

Si eseguono colorazioni speciali su richiesta.

STANDARD FEATURES

Adjustable steering column with connection for hydraulic power steering.

Tilt adjustment of 20° toward the operator and 5° toward windshield by lever.

Telescopic height adjustment of 60 mm. by lever.

Black/grey ABS plastic covers.

Instrumentation and electric components per customer request.

Complete with wiring loom.

Different colours on demand.

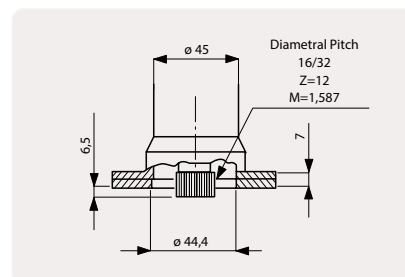
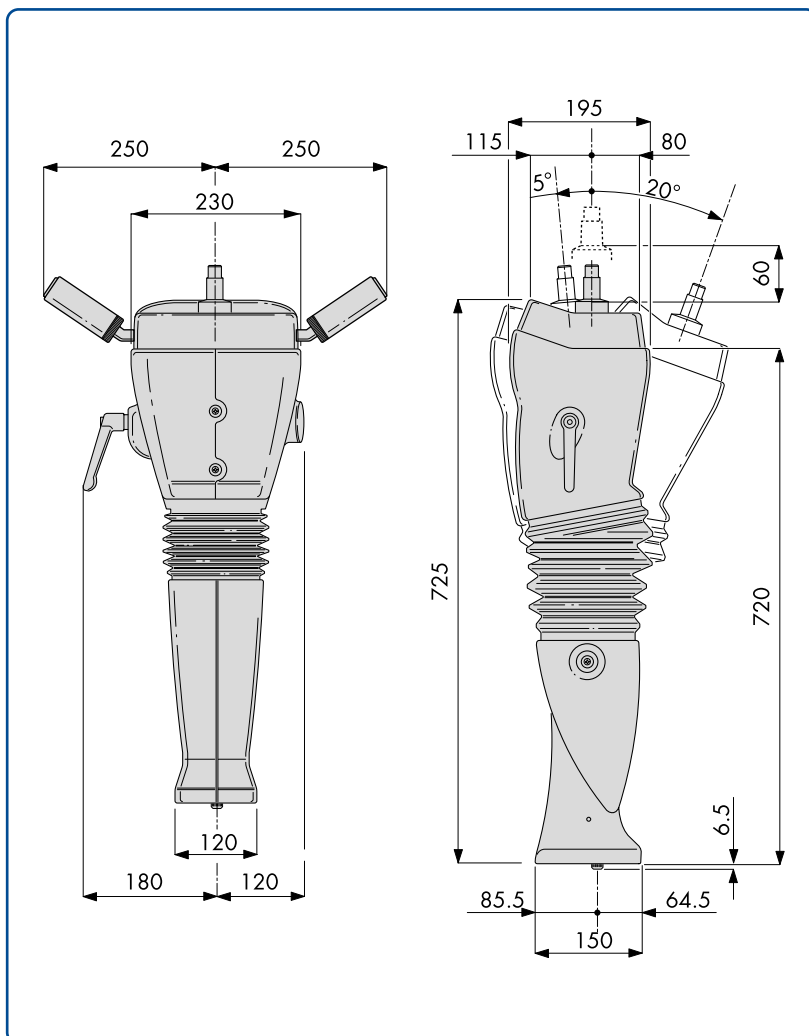

Attacco standard idroguida
Standard hydraulic steering joint

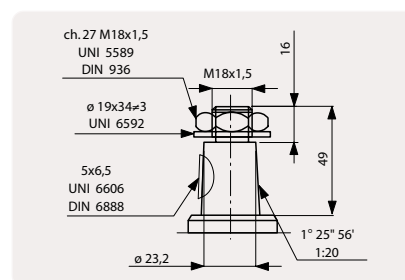

Cono fissaggio volante
Standard cone

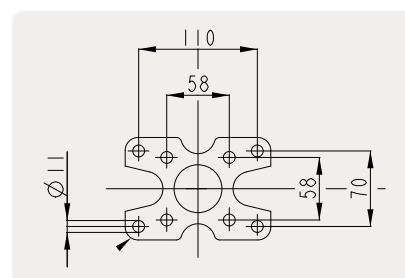

Modello standard
Standard flanges

CL830 short

BCH

metal pillar



tilt



60 mm



CARATTERISTICHE STANDARD

Colonna guida regolabile completa di piantone con attacco per idroguida.

Regolazione dell'inclinazione di 20° in direzione del conducente e di 5° sul lato opposto mediante leva.

Regolazione telescopica dell'altezza di 60 mm, mediante leva.

Rivestimento in materiale plastico ABS nero/grigio.

Strumentazione e apparecchiature di comando componibili secondo l'esigenza del cliente.

Completa di cablaggio.

Si eseguono colorazioni speciali su richiesta.

STANDARD FEATURES

Adjustable steering column with connection for hydraulic power steering.

Tilt adjustment of 20° toward the operator and 5° toward windshield by lever.

Telescopic height adjustment of 60 mm. by lever.

Black/grey ABS plastic covers.

Instrumentation and electric components per customer request.

Complete with wiring loom.

Different colours on demand.

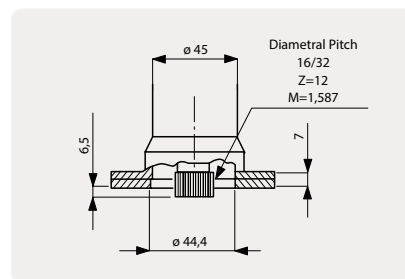
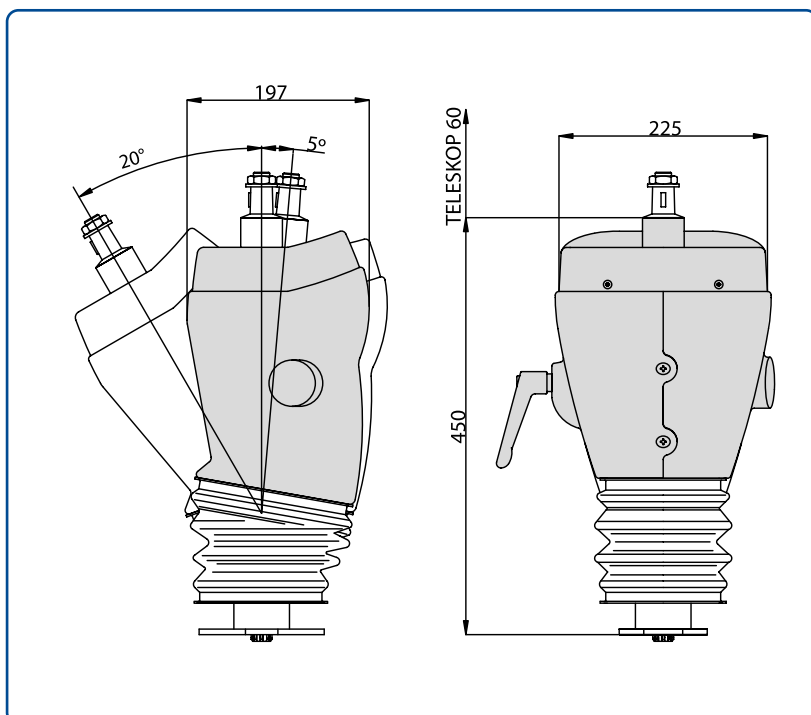
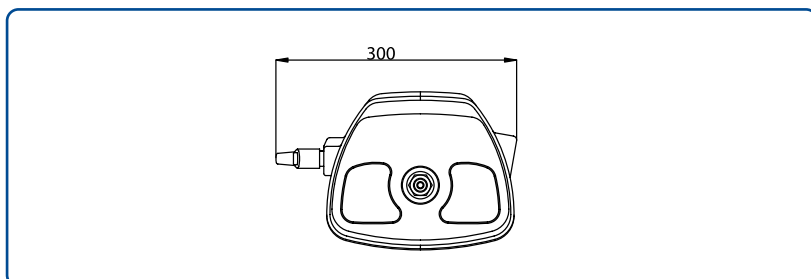

Attacco standard idroguida
Standard hydraulic steering joint

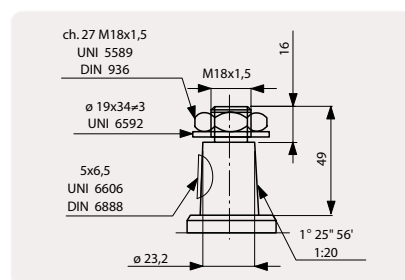

Cono fissaggio volante
Standard cone

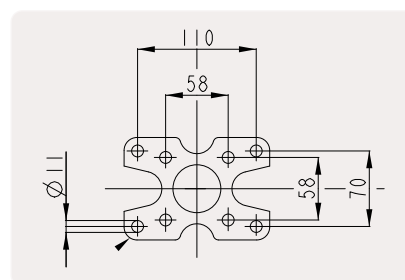

Modello standard
Standard flanges

CL850

BCH

metal pillar



tilt



60 mm



CARATTERISTICHE STANDARD

Colonna guida regolabile completa di piantone con attacco per idroguida.

Regolazione dell'inclinazione di 20° in direzione del conducente e di 5° sul lato opposto mediante leva.

Regolazione telescopica dell'altezza di 60 mm, mediante leva.

Rivestimento in materiale plastico ABS nero/grigio.

Strumentazione e apparecchiature di comando componibili secondo l'esigenza del cliente.

Completa di cablaggio.

Si eseguono colorazioni speciali su richiesta.

STANDARD FEATURES

Adjustable steering column with connection for hydraulic power steering.

Tilt adjustment of 20° toward the operator and 5° toward windshield by lever.

Telescopic height adjustment of 60 mm. by lever.

Black/grey ABS plastic covers.

Instrumentation and electric components per customer request.

Complete with wiring loom.

Different colours on demand.

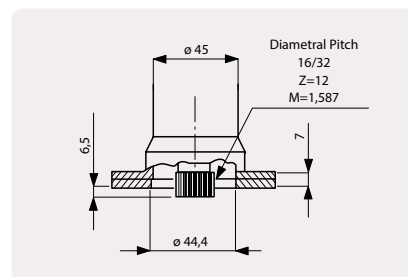
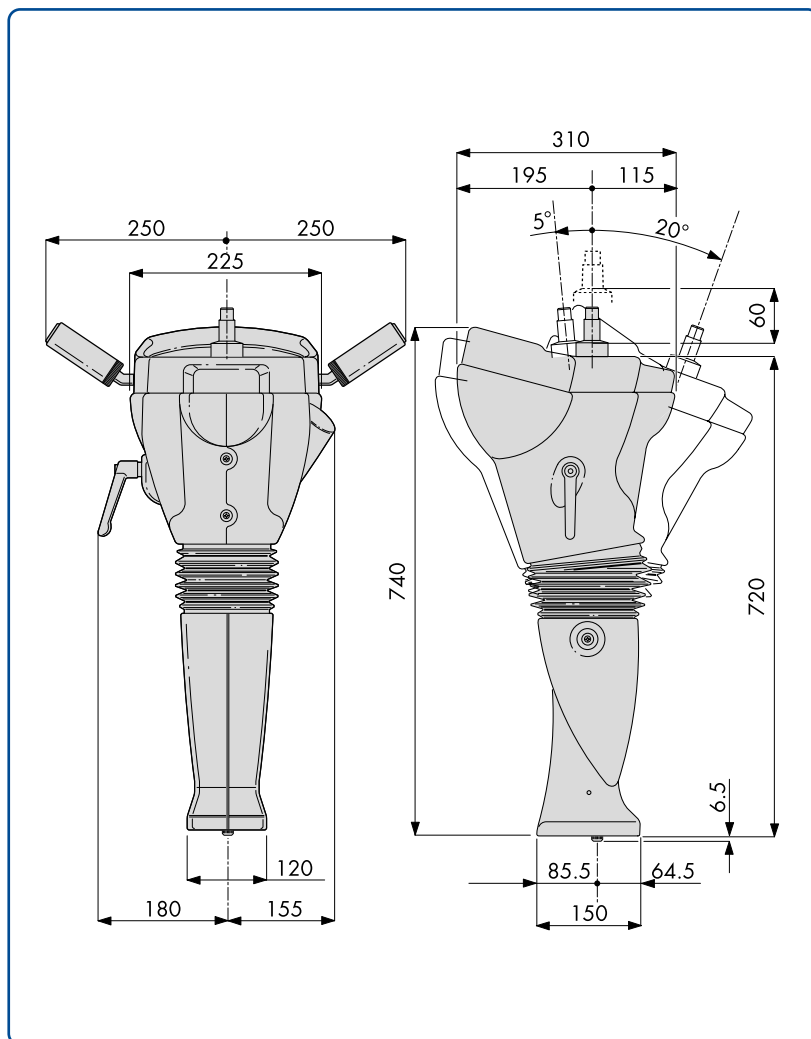

Attacco standard idroguida
Standard hydraulic steering joint

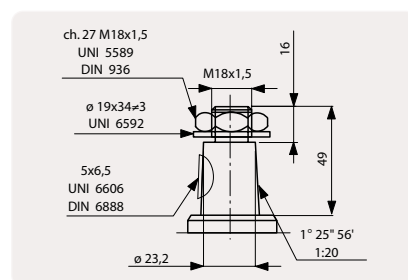

Cono fissaggio volante
Standard cone

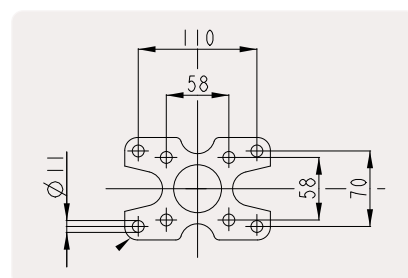

Modello standard
Standard flanges

CL850 short

BCH

metal pillar



tilt



60 mm



CARATTERISTICHE STANDARD

Colonna guida regolabile completa di piantone con attacco per idroguida.

Regolazione dell'inclinazione di 20° in direzione del conducente e di 5° sul lato opposto mediante leva.

Regolazione telescopica dell'altezza di 60 mm, mediante leva.

Rivestimento in materiale plastico ABS nero/grigio.

Strumentazione e apparecchiature di comando componibili secondo l'esigenza del cliente.

Completa di cablaggio.

Colorazione standard: nero.

Si eseguono colorazioni speciali su richiesta.

STANDARD FEATURES

Adjustable steering column with connection for hydraulic power steering.

Tilt adjustment of 20° toward the operator and 5° toward windshield by lever.

Telescopic height adjustment of 60 mm. by lever.

Black/grey ABS plastic covers.

Instrumentation and electric components per customer request.

Complete with wiring loom.

Standard colour: black.

Different colours on demand.

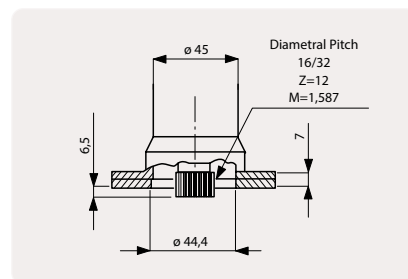
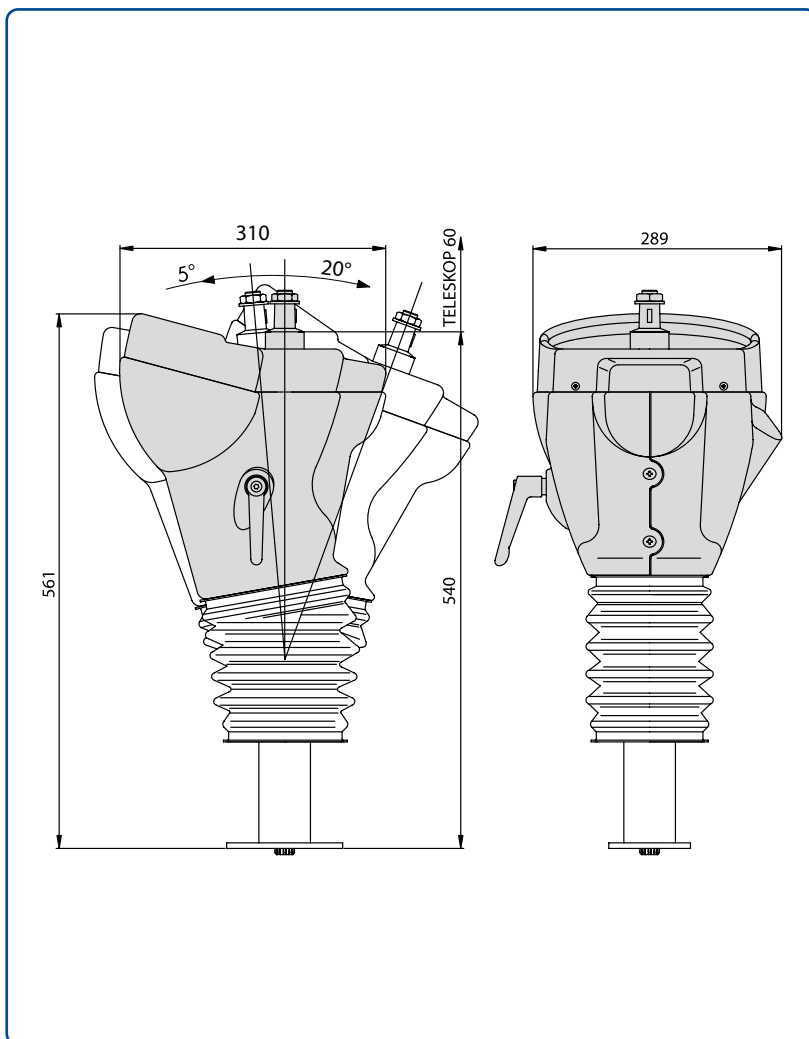

Attacco standard idroguida
Standard hydraulic steering joint

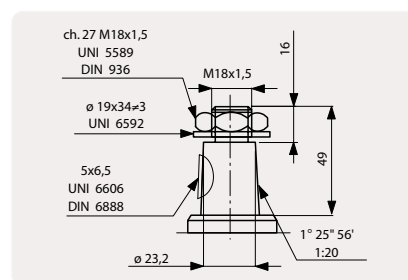

Cono fissaggio volante
Standard cone

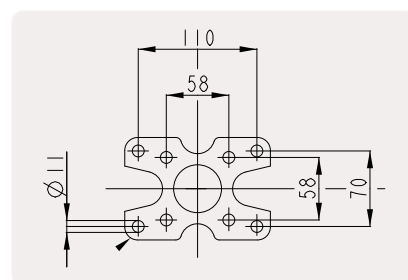

Modello standard
Standard flanges

CL870

CBK

metal pillar



tilt



60 mm



CARATTERISTICHE STANDARD

Colonna guida regolabile completa di piantone con attacco per idroguida.

Regolazione dell'inclinazione di 30° in direzione del conducente e di 5° sul lato opposto mediante pedale.

Regolazione telescopica mediante maniglia 60mm.

Rivestimento in materiale plastico ABS grigio.

Strumentazione e apparecchiature di comando componibili secondo l'esigenza del cliente.

Completa di cablaggio.

Colorazione standard: grigio.

Si eseguono colorazioni speciali su richiesta.

STANDARD FEATURES

Adjustable steering column with connection for hydraulic power steering.

Tilt adjustment of 30° toward the operator and 5° tilt toward windshield by foot pedal.

Telescopic lever adjustment of 60 mm.

Grey ABS plastic covers.

Instrumentation and electric components per customer request.

Complete with wiring loom.

Standard colour: grey.

Different colours on demand.

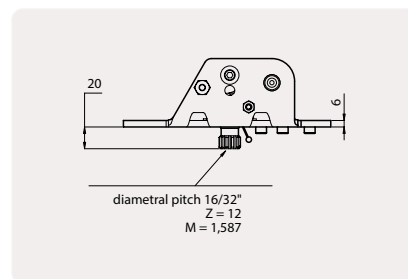
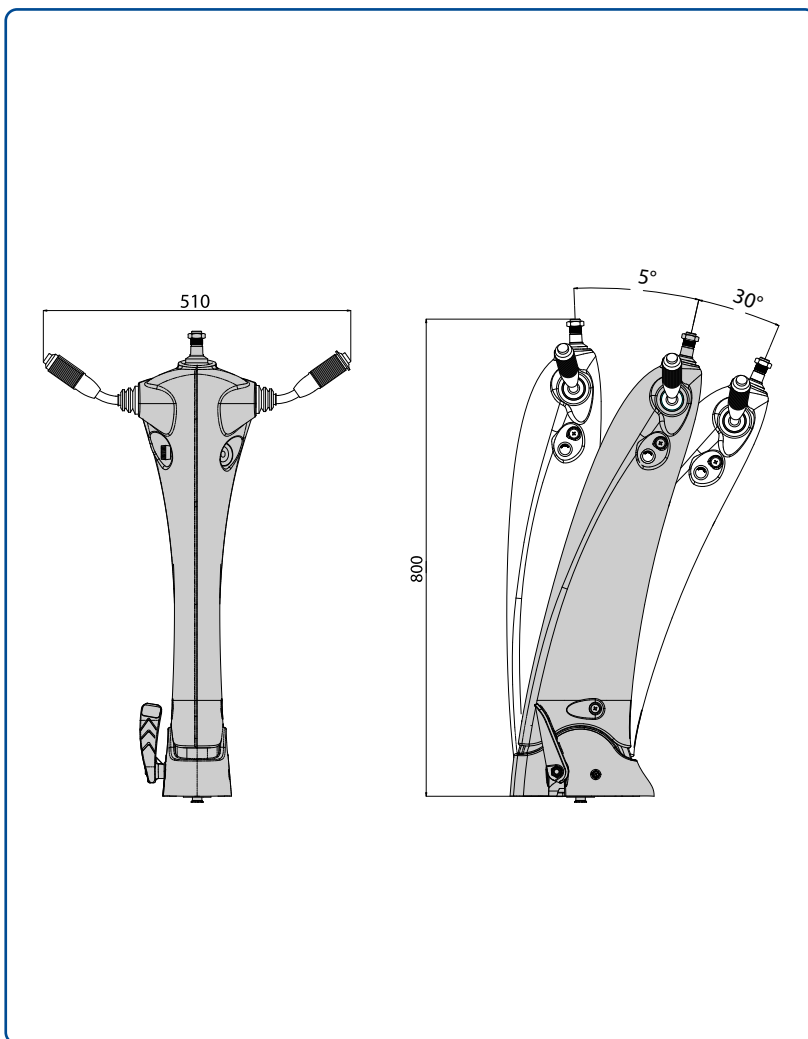

Attacco standard idroguida
Standard hydraulic steering joint

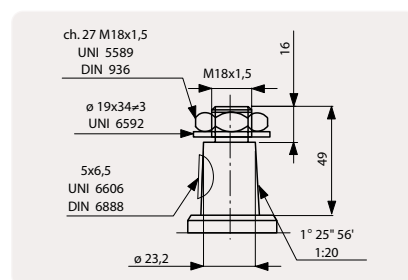

Cono fissaggio volante
Standard cone

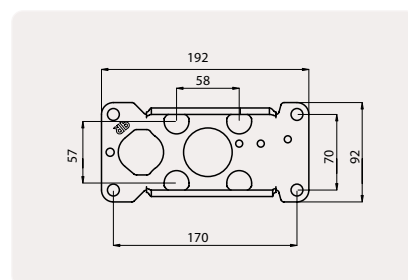

Modello standard
Standard flanges

CL900

BCH

metal pillar



tilt



60 mm



CARATTERISTICHE STANDARD

Colonna guida regolabile completa di piantone con attacco per idroguida.

Regolazione dell'inclinazione di 20° in direzione del conducente e di 5° sul lato opposto mediante leva.

Regolazione telescopica dell'altezza di 60 mm, mediante leva.

Rivestimento in materiale plastico ABS nero/grigio.

Strumentazione e apparecchiature di comando componibili secondo l'esigenza del cliente.

Completa di cablaggio.

Colorazione standard: nero.

Si eseguono colorazioni speciali su richiesta.

STANDARD FEATURES

Adjustable steering column with connection for hydraulic power steering.

Tilt adjustment of 20° toward the operator and 5° toward windshield by lever.

Telescopic height adjustment of 60 mm. by lever.

Black/grey ABS plastic covers.

Instrumentation and electric components per customer request.

Complete with wiring loom.

Standard colour: black.

Different colours on demand.

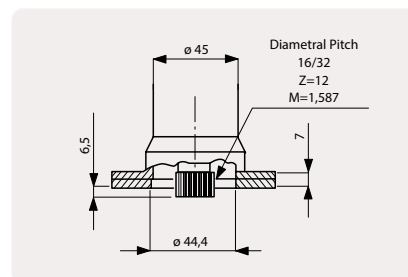
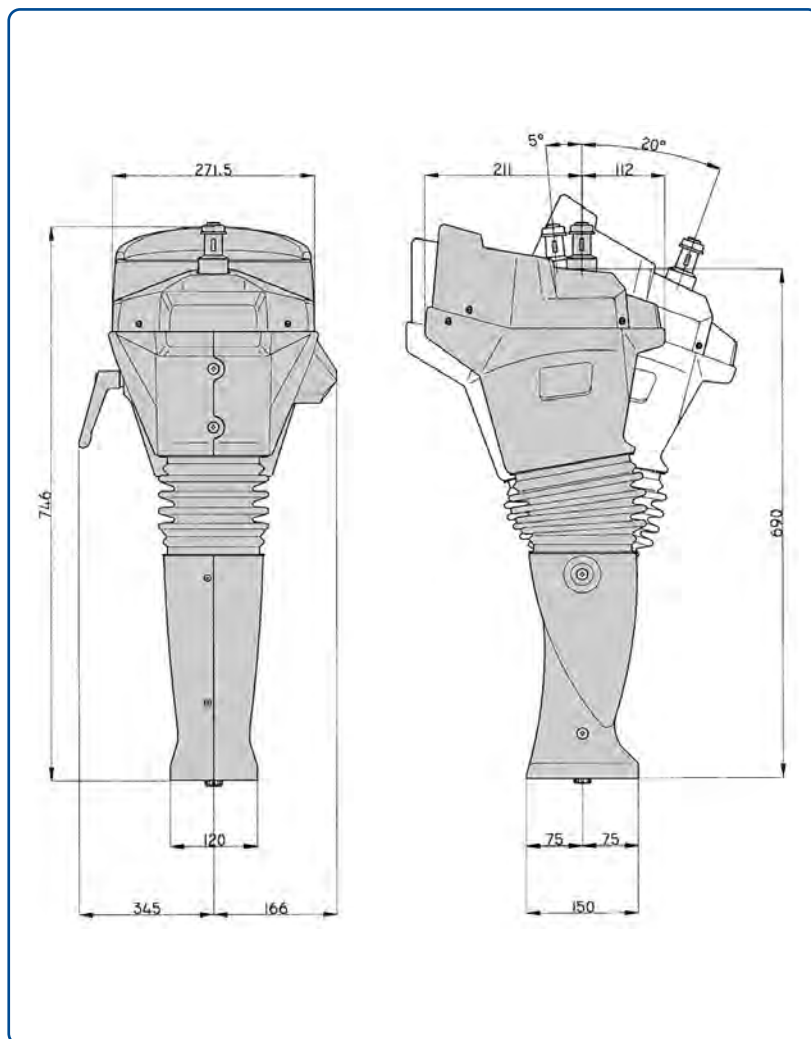

Attacco standard idroguida
Standard hydraulic steering joint

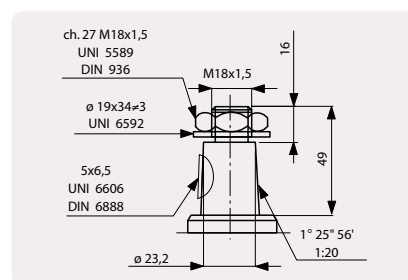

Cono fissaggio volante
Standard cone

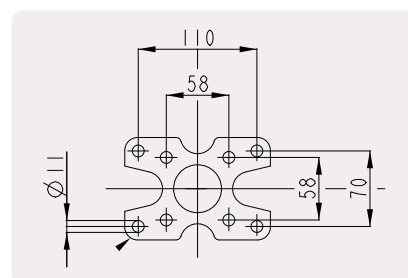

Modello standard
Standard flanges

CL900 short

BCH

metal pillar



tilt



60 mm

CARATTERISTICHE STANDARD

Colonna guida regolabile completa di piantone con attacco per idroguida.

Regolazione dell'inclinazione di 20° in direzione del conducente e di 5° sul lato opposto mediante leva.

Regolazione telescopica dell'altezza di 60 mm, mediante leva.

Rivestimento in materiale plastico ABS nero/grigio.

Strumentazione e apparecchiature di comando componibili secondo l'esigenza del cliente.

Completa di cablaggio.

Colorazione standard: nero.

Si eseguono colorazioni speciali su richiesta.

STANDARD FEATURES

Adjustable steering column with connection for hydraulic power steering.

Tilt adjustment of 20° toward the operator and 5° toward windshield by lever.

Telescopic height adjustment of 60 mm. by lever.

Black/grey ABS plastic covers.

Instrumentation and electric components per customer request.

Complete with wiring loom.

Standard colour: black.

Different colours on demand.

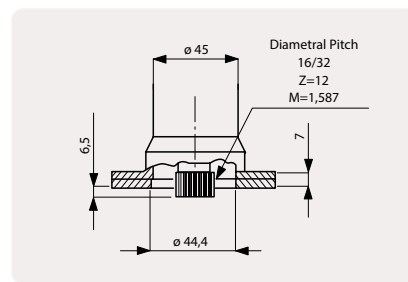
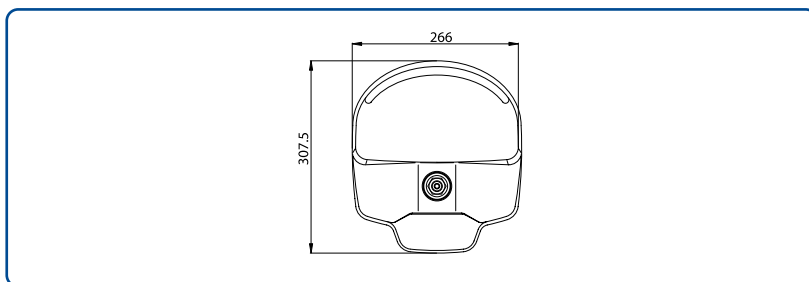

Attacco standard idroguida
Standard hydraulic steering joint

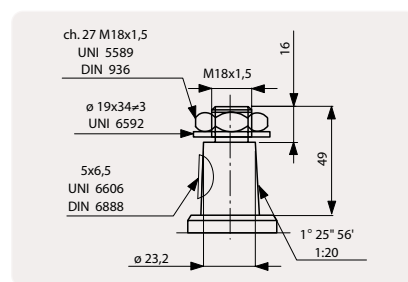
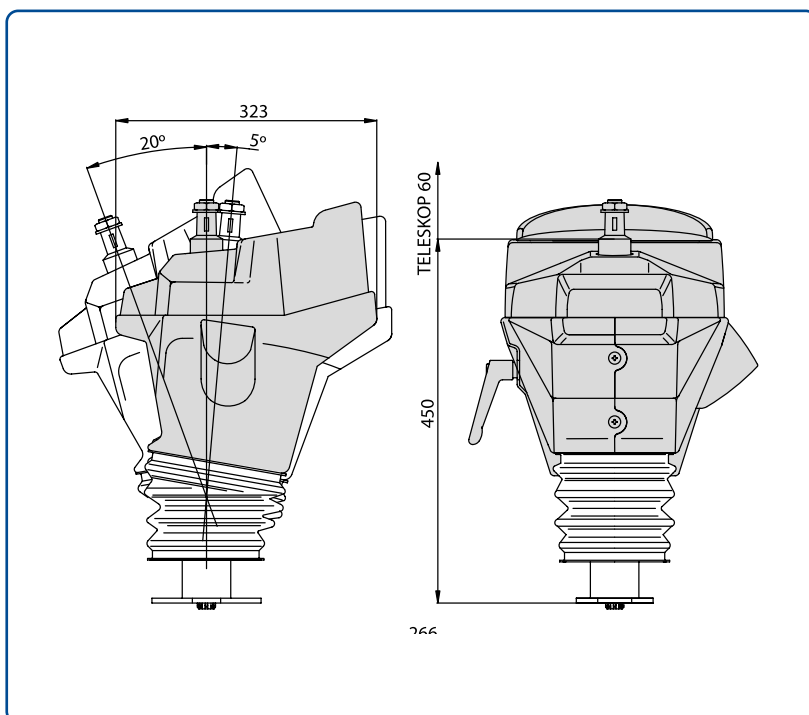

Cono fissaggio volante
Standard cone

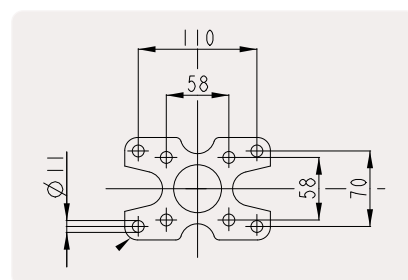

Modello standard
Standard flanges

CL950 short

BCH



metal pillar

tilt

60 mm



CARATTERISTICHE STANDARD

Colonna guida regolabile completa di piantone con attacco per idroguida.

Regolazione dell'inclinazione di 20° in direzione del conducente e di 5° sul lato opposto mediante leva.

Regolazione telescopica di 60 mm mediante leva.

Rivestimento in materiale plastico ABS nero/grigio.

Strumentazione e apparecchiature di comando componibili secondo l'esigenza del cliente.

Completa di cablaggio.

Si eseguono colorazioni speciali su richiesta.

STANDARD FEATURES

Adjustable steering column with connection for hydraulic power steering.

Tilt adjustment of 20° toward the operator and 5° toward windshield by lever.

Telescopic height adjustment of 60 mm by lever.

Black/grey ABS plastic covers.

Instrumentation and electric components on customer request.

Complete with wiring loom.

Different colours on demand.

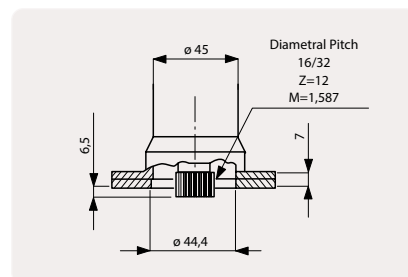
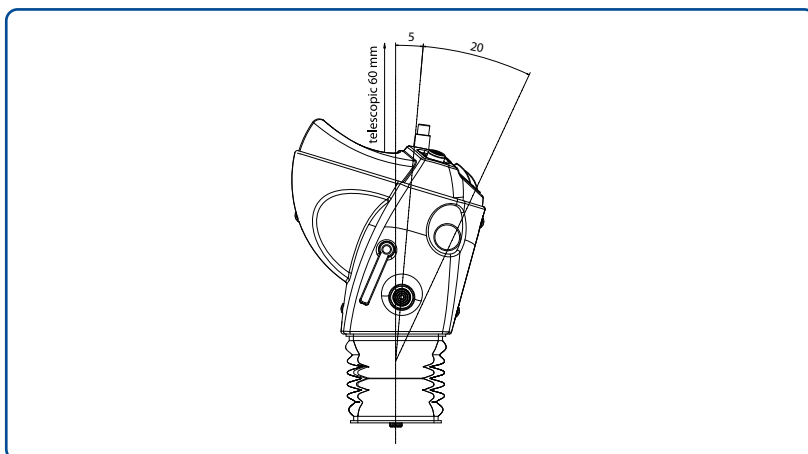

Attacco standard idroguida
Standard hydraulic steering joint

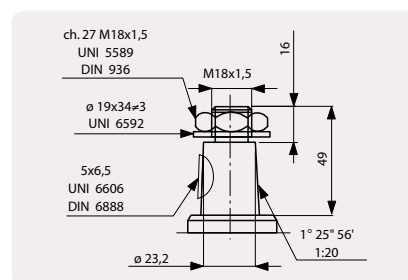
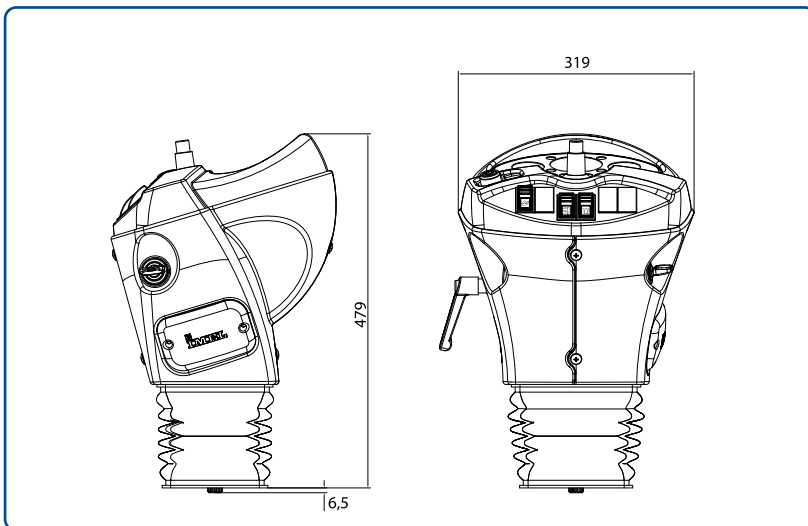

Cono fissaggio volante
Standard cone

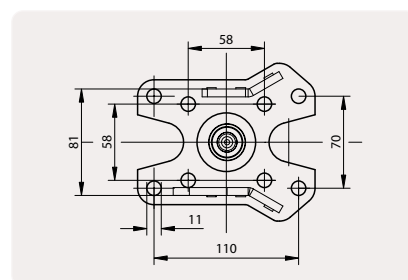

Modello standard
Standard flanges

CL2000

BCH



metal pillar

tilt

60 mm



CARATTERISTICHE STANDARD

Colonna guida regolabile completa di piantone con attacco per idroguida.

Regolazione dell'inclinazione di 20° in direzione del conducente e di 5° sul lato opposto mediante leva.

Regolazione telescopica dell'altezza di 60 mm, mediante leva.

Rivestimento in materiale plastico ABS nero/grigio.

Strumentazione e apparecchiature di comando componibili secondo l'esigenza del cliente.

Completa di cablaggio.

Si eseguono colorazioni speciali su richiesta.

STANDARD FEATURES

Adjustable steering column with connection for hydraulic power steering.

Tilt adjustment of 20° toward the operator and 5° toward windshield by lever.

Telescopic height adjustment of 60 mm. by lever.

Black/grey ABS plastic covers or soft touch.

Instrumentation and electric components per customer request.

Complete with wiring loom.

Different colours on demand.

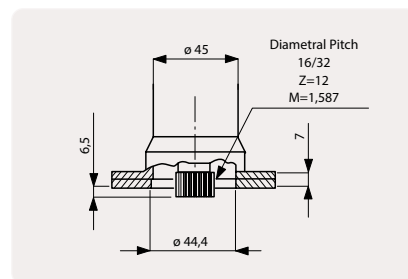
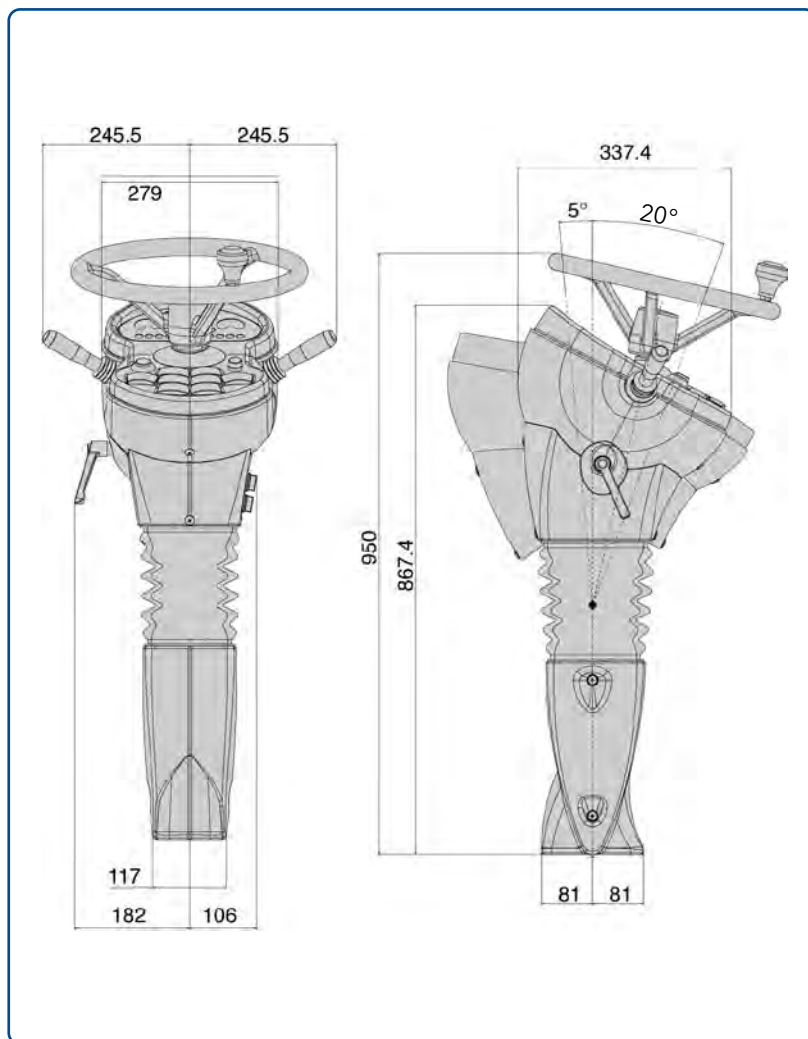

Attacco standard idroguida
Standard hydraulic steering joint

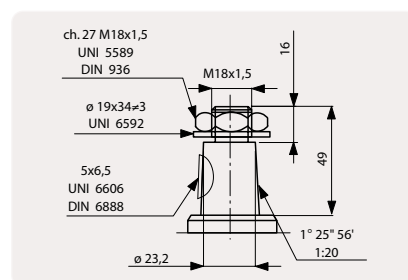

Cono fissaggio volante
Standard cone

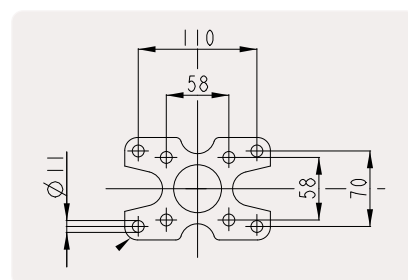

Modello standard
Standard flanges

CL2000 short

BCH

metal pillar



tilt



60 mm



CARATTERISTICHE STANDARD

Colonna guida regolabile completa di piantone con attacco per idroguida.

Regolazione dell'inclinazione di 20° in direzione del conducente e di 5° sul lato opposto mediante leva.

Regolazione telescopica dell'altezza di 60 mm, mediante leva.

Rivestimento in materiale plastico ABS nero/grigio.

Strumentazione e apparecchiature di comando componibili secondo l'esigenza del cliente.

Completa di cablaggio.

Si eseguono colorazioni speciali su richiesta.

STANDARD FEATURES

Adjustable steering column with connection for hydraulic power steering.

Tilt adjustment of 20° toward the operator and 5° toward windshield by lever.

Telescopic height adjustment of 60 mm. by lever.

Black/grey ABS plastic covers.

Instrumentation and electric components per customer request.

Complete with wiring loom.

Different colours on demand.

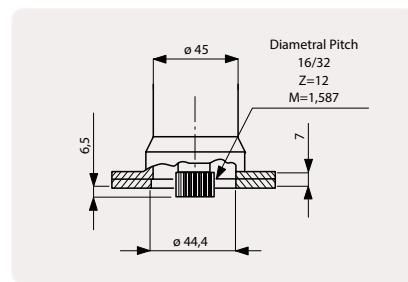
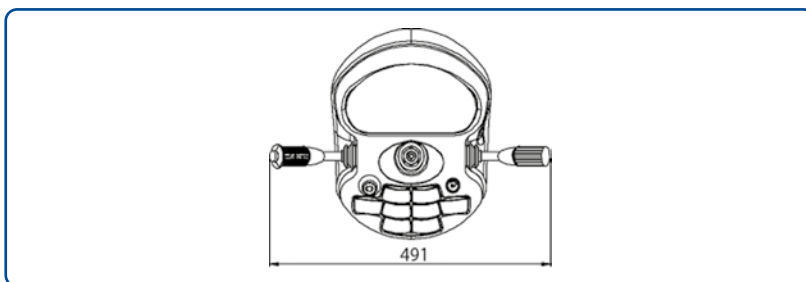

Attacco standard idroguida
Standard hydraulic steering joint

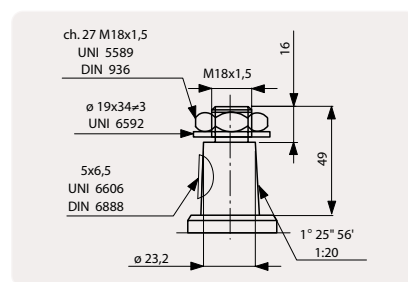
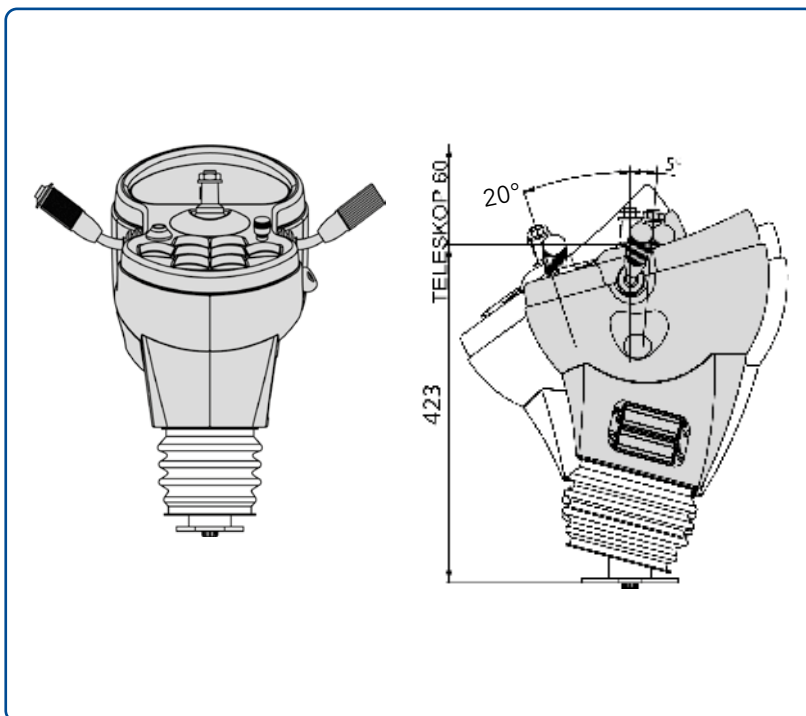

Cono fissaggio volante
Standard cone

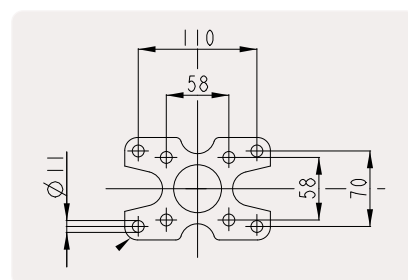

Modello standard
Standard flanges

CL2200

CBK

metal pillar



tilt



50 mm



GRUPPO COLONNA STERZO COMPLETA:

4 Coperture plastiche stampate in termoformatura (design e stampi di proprietà ama spa).

Modello fornibile con cablaggio elettrico (standard o personalizzato).

Modello fornibile con volante.

REGOLAZIONE INCLINABILE:

Fulcro alloggiato alla base della colonnetta.

Intervallo regolazione: 7° verso parabrezza, 19° verso conducente.

Sblocco tramite pedale.

Regolazione assistita da molla a gas.

REGOLAZIONE TELESCOPICA (OPZIONALE):

Alloggiata nella porzione superiore.

Intervallo regolazione: 50mm.

Sblocco tramite pomello alloggiato al centro del Volante.

COMPLETE STEERING MODULE INCLUDING:

Set of 4 plastic covers made via thermo-moulding vacuum system (design and tools are property of ama spa).

Option for wiring harness (standard or customized).

Option for steering wheel.

TILT ADJUSTMENT:

Pivot located at the base of the column.

Travel: 7° toward windshield, 19° toward operator.

Operated by a dedicated foot pedal.

Gas strut assisted.

TELESCOPIC ADJUSTMENT (OPTIONAL):

Located onto upper section.

Travel: 50mm.

Operated by a dedicated knob located onto steering wheel hub.

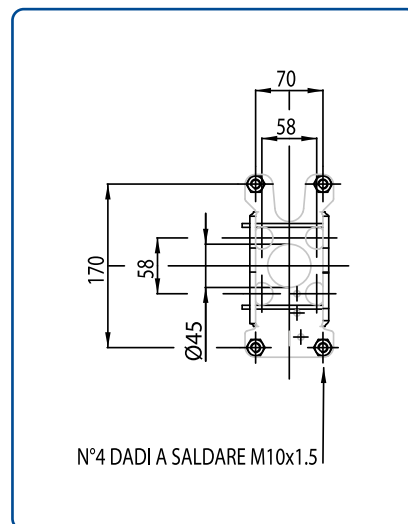
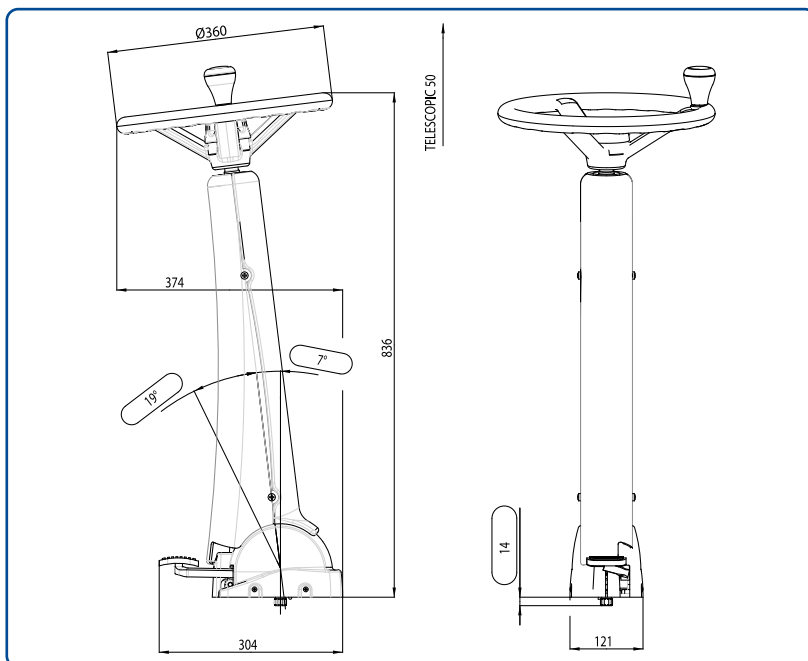

CL2300

CBK

metal pillar



tilt



50 mm



GRUPPO COLONNA STERZO COMPLETA:

4 Coperture plastiche stampate in termoformatura (design e stampe di proprietà ama spa).

Predisposizione per alloggiamento di 1 devio-guida SWF-Valeo (sinistro).

Modello fornibile con cablaggio elettrico (standard o personalizzato).

Modello fornibile con volante.

REGOLAZIONE INCLINABILE:

Fulcro alloggiato alla base della colonnetta.

Intervallo regolazione: 7° verso parabrezza, 19° verso conducente.

Sblocco tramite pedale.

Regolazione assistita da molla a gas.

REGOLAZIONE TELESCOPICA (OPZIONALE):

Alloggiata nella porzione superiore.

Intervallo regolazione: 50mm.

Sblocco tramite pomello alloggiato al centro del volante.

COMPLETE STEERING MODULE INCLUDING:

Set of 4 plastic covers made via thermo-moulding vacuum system (design and tools are property of ama spa).

Accommodation for 1 of SWF-Valeo stalk switch (LH).

Option for wiring harness (standard or customized).

Option for steering wheel.

TILT ADJUSTMENT:

Pivot located at the base of the column.

Travel: 7° toward windshield, 19° toward operator.

Operated by a dedicated foot pedal.

Gas strut assisted.

TELESCOPIC ADJUSTMENT (OPTIONAL):

Located onto upper section.

Travel: 50mm.

Operated by a dedicated knob located onto steering wheel hub.

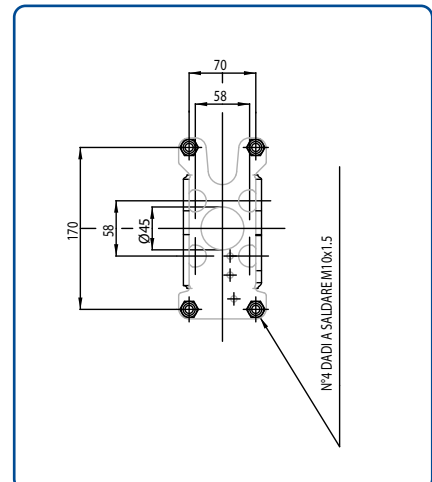
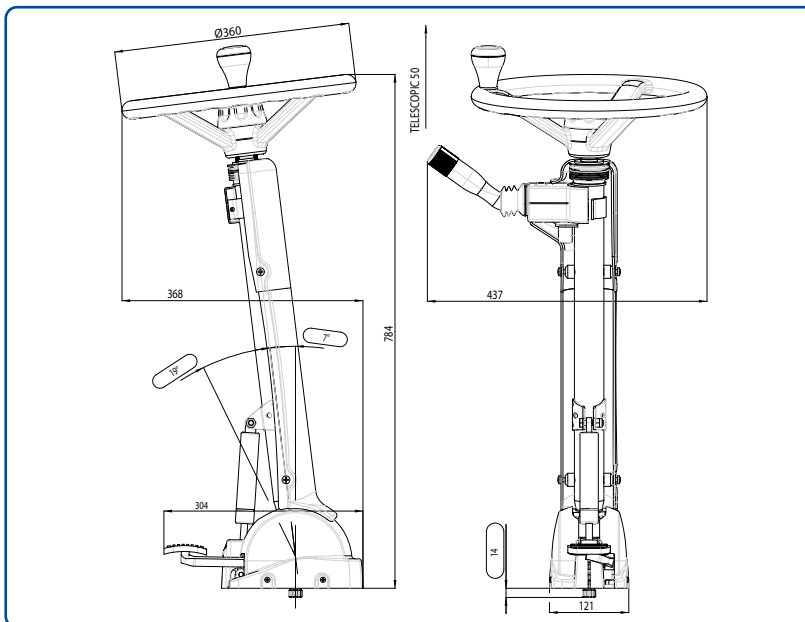

CL2302

CBK

metal pillar



tilt



50 mm



GRUPPO COLONNA STERZO COMPLETA:

4 Coperture plastiche stampate in termoformatura (design e stampe di proprietà ama spa).

Predisposizione per alloggiamento di 2 deviatori SWF-Valeo.

Modello fornibile con cablaggio elettrico (standard o personalizzato).

Modello fornibile con volante.

REGOLAZIONE INCLINABILE:

Fulcro alloggiato alla base della colonnetta.

Intervallo regolazione: 7° verso parabrezza, 19° verso conducente.

Sblocco tramite pulsante.

Regolazione assistita da molla a gas.

REGOLAZIONE TELESCOPICA (OPZIONALE):

Alloggiata nella porzione superiore.

Intervallo regolazione: 50mm.

Sblocco tramite pomello alloggiato al centro del volante.

COMPLETE STEERING MODULE INCLUDING:

Set of 4 plastic covers made via thermo-moulding vacuum system (design and tools are property of ama spa).

Accommodation for 2 of SWF-Valeo stalk switch.

Option for wiring harness (standard or customized).

Option for steering wheel.

TILT ADJUSTMENT:

Pivot located at the base of the column.

Travel: 7° toward windshield, 19° toward operator.

Operated by a dedicated button.

Gas strut assisted.

TELESCOPIC ADJUSTMENT (OPTIONAL):

Located onto upper section.

Travel: 50mm.

Operated by a dedicated knob located onto steering wheel hub.

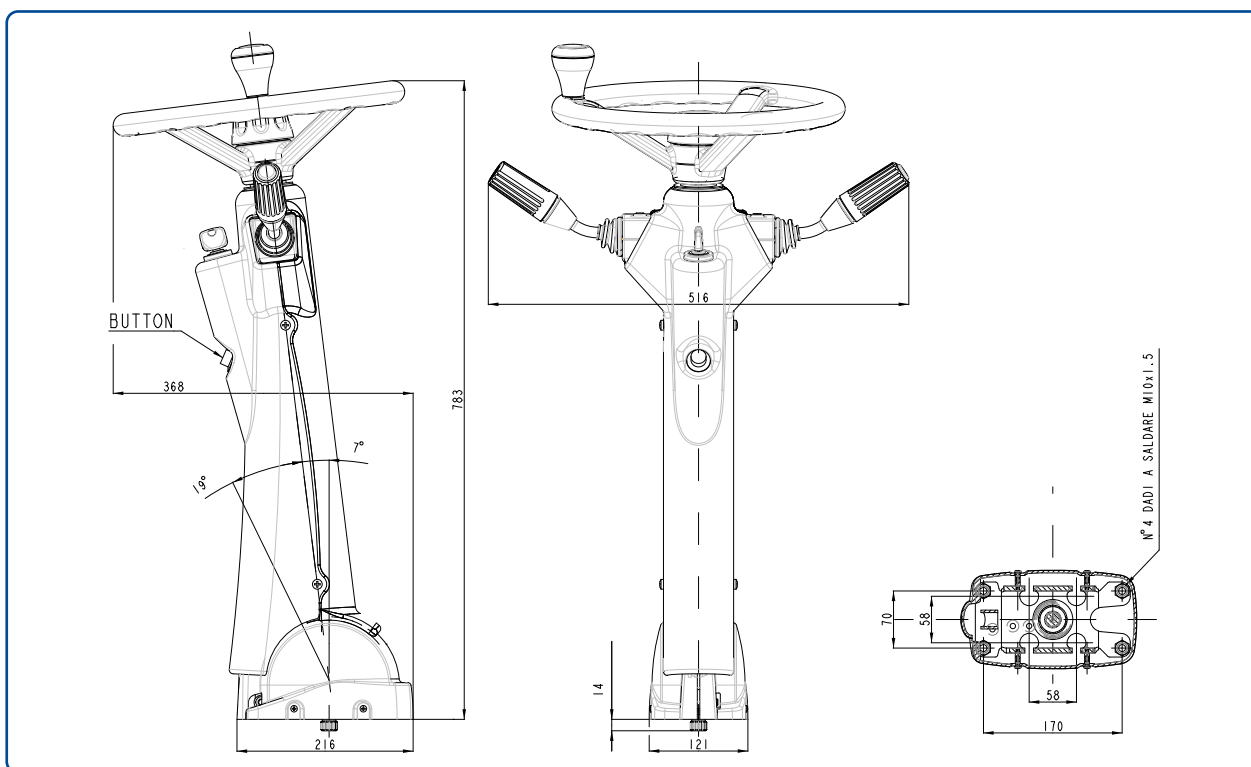

CONI STANDARD

STANDARD CONE

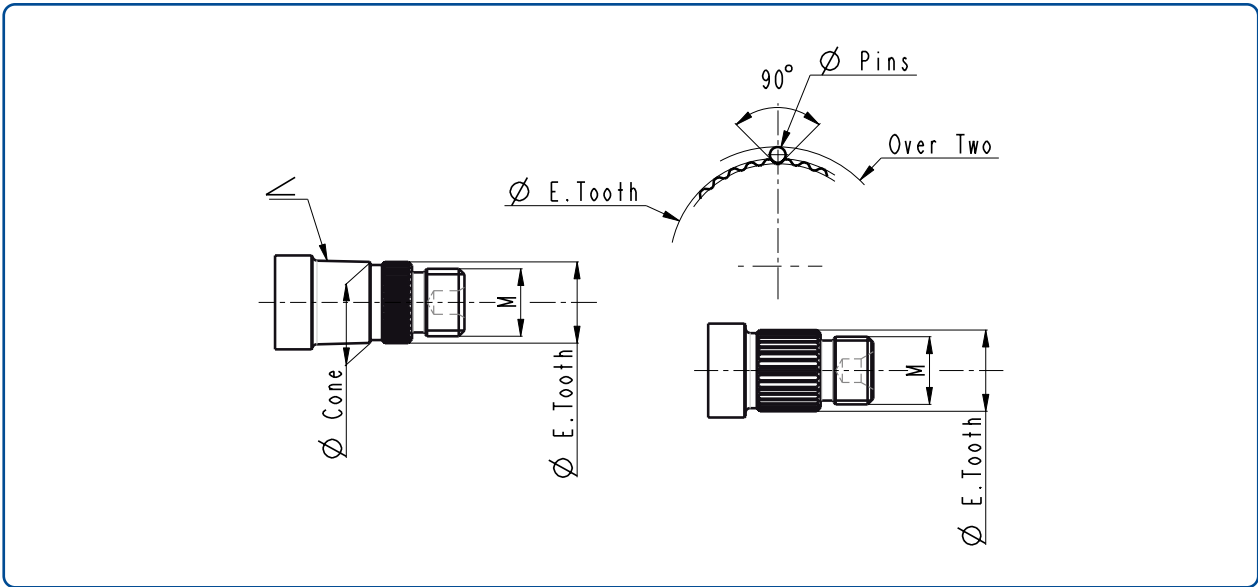

PERTEX CONO STANDARD: DENTE Z=
PERTEX STANDARD CONE: TOOTH Z=

CONE NUMBER	THREAD M	CONE TOPER	< CONE	Ø CONE	Ø E. TOOTH	TOOTH	Ø PINS	OVER TWO
3	M=18x1.5	1:16	1°47'23"	21.0	20.5	36	1.35	22.16
4	M=18x1.5	1:19.26	1°29'14"	21.55	21.7	36	1.587	24.12
5	M=18x1.5	1:19.26	1°29'14"	21.84	21.7	36	1.587	24.12
20	M=16x1.5	1:12	2°23'10"	17.9	17.4	40	1.320	19.48
24	M=16x1.5	1.46:20	2°5'25"	18.16	17.5	36	1.35	19.35
29	M=14x1.5	1:4.15	6°52'03"	16.5	15.8	36	1.320	17.72
35	M=16x1.5	1:3.43	8°17'37"	19.4	19.0	48	0.96	20.1

PERTEX ATTACCO RUOTA: DENTE Z=
PERTEX WHEEL ATTACK: TOOTH Z=

CONE NUMBER	THREAD M	CONE TOPER	< CONE	Ø CONE	Ø E. TOOTH	TOOTH	Ø PINS	OVER TWO
18	M=16x2	-	-	-	19.6	38	0.96	20.43
28	M=18x1.5	-	-	-	23.95	24	2.25	26.65
32	M=18x1.5	-	-	-	21.7	36	1.587	24.12

PERTEX CONO STANDARD: LINGUETTA A DISCO 5X6.5
PERTEX STANDARD CONE: WOODRUFF 5X6.5

CONE NUMBER	THREAD M	CONE TOPER	< CONE	Ø CONE
1	M=18x1.5	1:20	1°25'55"	23.2
2	M=18x1.5	1:20	1°25'55"	20.53
6	M=16x1.5	1:8	3°34'34"	18.6
7	M=16x1.5	1:7.5	3°48'50"	18.2
21	M=18x1.5	1:16	1°47'23"	20.0

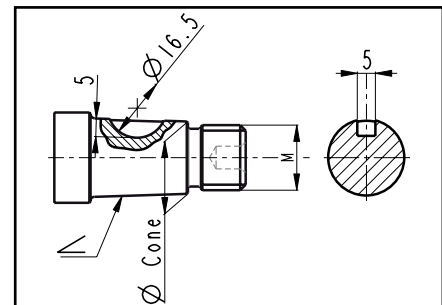

SERIE 6 Polypropylene



- ACC2100
- ACC2101 knob
- ACC0018
- PP

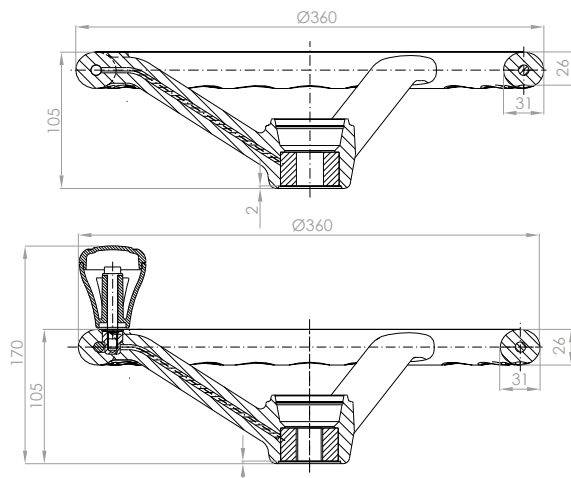

Part Number	A	B	C	D	Teeth	Taper	E	F	G	H
VOL1636C2	45	26	/	/	/	1:7,5	19,20	/	11,65	5
VOL1636C5	45	26	/	/	/	1:7,5	21,60	/	12,30	5
VOL1636DA	45	26	/	/	/	1:20	24,80	/	15,40	5
VOL1636D4	45	26	13	20,78	36	1:19,26	23,02	22,04	/	/
VOL163618	45	26	/	18,30	36	/	/	19,80	/	/

SERIE 9 Polypropylene



- knob
- PP

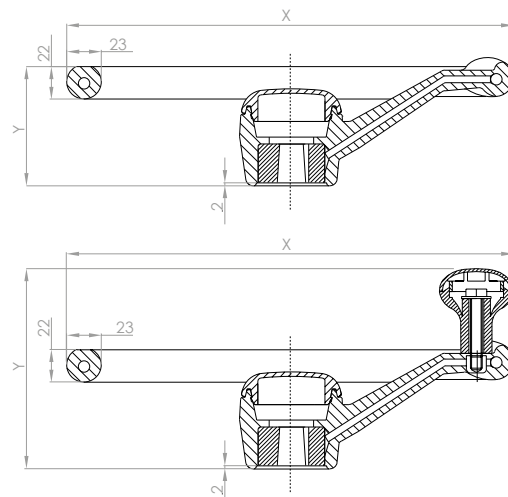

Code Part Number	X	Y	A	B	C	D	Denti Teeth	Cono Taper	E	F	G	H
VOL1930C2	300	81	45	26	/	/	/	1:7,5	19,20	/	11,65	5
VOL1930C2P	300	131	45	26	/	/	/	1:7,5	19,20	/	11,65	5
VOL1930DA	300	81	45	26	/	/	/	1:20	24,80	/	15,40	5
VOL1936C2	360	100	45	26	/	/	/	1:7,5	19,20	/	11,65	5
VOL1936C5	360	100	45	26	/	/	/	1:7,5	21,60	/	12,30	5
VOL1936DA	360	100	45	26	/	/	/	1:20	24,80	/	15,40	5
VOL1936DAP	360	150	45	26	/	/	/	1:20	24,80	/	15,40	5
VOL193680	360	130	45	26	16	16,60	40	1:12	18,86	17,82	/	/

SERIE 10 Polypropylene

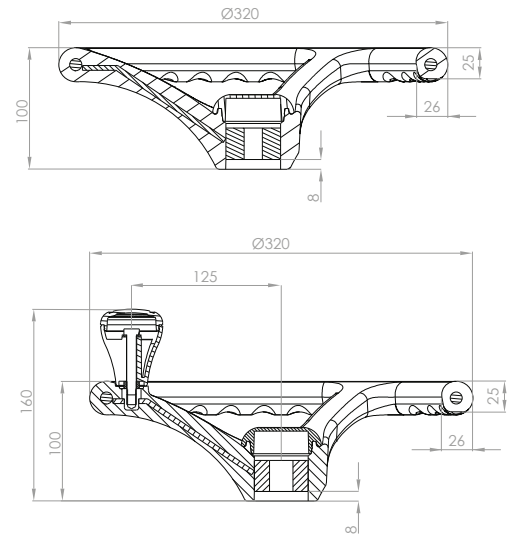

Code Part Number	A	B	C	D	Denti Teeth	Cono Taper	E	F	G	H
VOL1032C2	45	26	/	/	/	1:7,5	19,20	/	11,65	5
VOL1032DA	45	26	/	/	/	1:20	24,80	/	15,40	5
VOL1032D4	45	26	13	20,78	36	1:19,26	23,02	22,04	/	/
VOL1032ET	45	26	18	16,627	40	1:12	18,86	17,826	/	/
VOL1032ET2	45	26	/	/	/	1:7,6	19,64	/	12,40	5
VOL1032MI	45	26	/	/	/	1:20	17,40	/	12	5

SERIE 11 Polyurethane

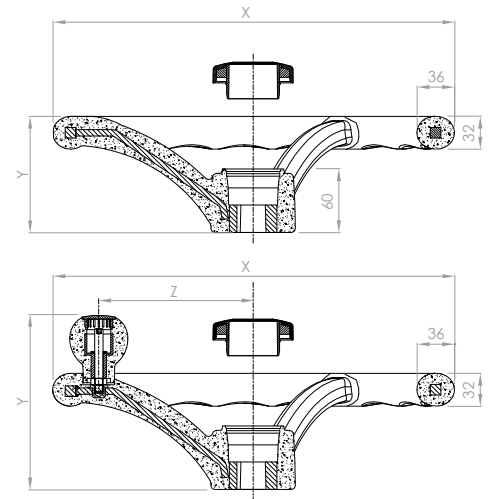
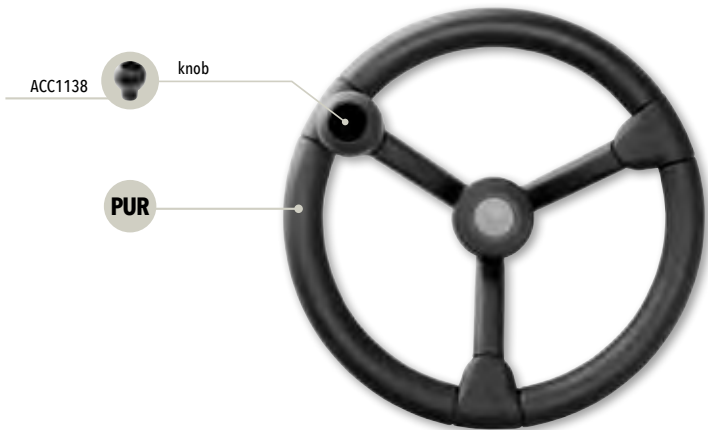

Part Number	X	Y	Z	A	B	C	D	Teeth	Taper	E	F	G	H
VOL11138DA	380	110	/	45	26	/	/	/	1:20	23,20	/	15,40	5
VOL11138DAP	380	165	143	45	26	/	/	/	1:20	23,20	/	15,40	5
VOL11138D4	380	110	/	45	26	13	20,78	36	1:19,26	21,50	22,04	/	/
VOL11138D4P	380	165	143	45	26	13	20,78	36	1:19,26	21,50	22,04	/	/
VOL11138T3	380	110	/	45	26	14,50	19,38	36	1:16	20,95	20,68	/	/
VOL11138T3P	380	165	143	45	26	14,50	19,38	36	1:16	20,95	20,68	/	/
VOL11138AU	380	110	/	45	26	/	/	/	1:20	20,53	/	14,30	5
VOL11138AUP	380	165	143	45	26	/	/	/	1:20	20,53	/	14,30	5
VOL111405DA	405	125	/	45	26	/	/	/	1:20	23,20	/	15,40	5
VOL111405DAP	405	182	161	45	26	/	/	/	1:20	23,20	/	15,40	5
VOL111405D4	405	125	/	45	26	13	20,78	36	1:19,26	21,50	22,04	/	/
VOL111405D4P	405	182	161	45	26	13	20,78	36	1:19,26	21,50	22,04	/	/
VOL111405T3	405	125	/	45	26	14,50	19,38	36	1:16	20,95	20,68	/	/
VOL111405T3P	405	182	161	45	26	14,50	19,38	36	1:16	20,95	20,68	/	/

SERIE 12 Polyurethane

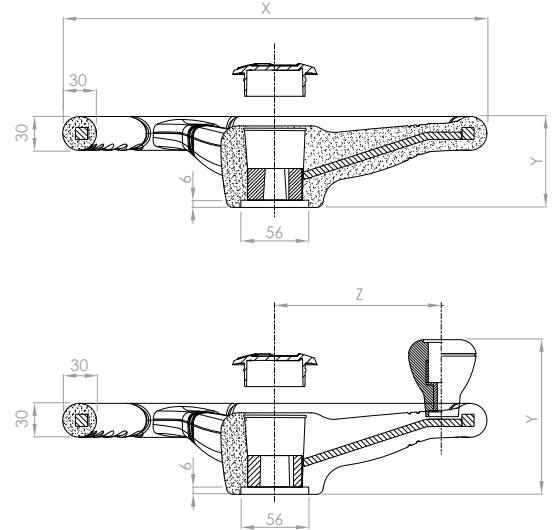

Part Number	X	Y	Z	A	B	C	D	Teeth	Taper	E	F	G	H
VOL11235DA	350	75	/	45	26	/	/	/	1:20	23,20	/	15,40	5
VOL11235DAP	350	128	138	45	26	/	/	/	1:20	23,20	/	15,40	5
VOL11235D4	350	75	/	45	26	13	20,78	36	1:19,26	21,50	22,04	/	/
VOL11235D4P	350	128	138	45	26	13	20,78	36	1:19,26	21,50	22,04	/	/
VOL11235T3	350	75	/	45	26	14,50	19,38	36	1:16	20,95	20,68	/	/
VOL11235T3P	350	128	138	45	26	14,50	19,38	36	1:16	20,95	20,68	/	/
VOL11235C2	350	75	/	45	26	/	/	/	1:7,9	15,90	/	11,65	5
VOL11235C2P	350	128	138	45	26	/	/	/	1:7,9	20,53	/	14,30	5

SERIE 18 Polyurethane

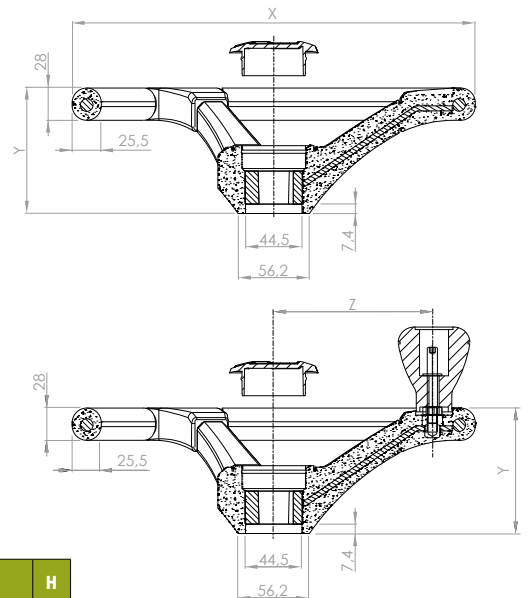
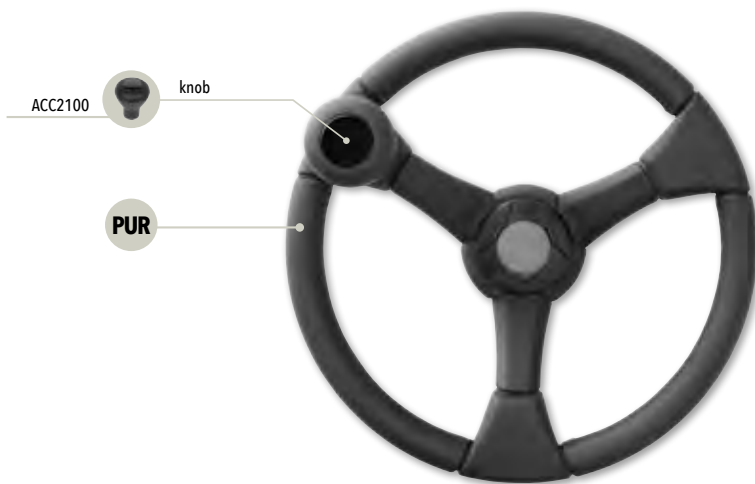

PART NUMBER	X	Y	Z	A	B	C	D	TEETH	TAPER	E	F	G	H
VOL1832AU	320	100	/	45	26	/	/	/	1:20	23,20	/	15,40	5
VOL1832DA	320	100	/	45	26	/	/	/	1:20	23,20	/	15,40	5
VOL1832DAP	320	162	125	45	26	/	/	/	1:20	23,20	/	15,40	5
VOL1832D4	320	100	/	45	26	13	20,78	36	1:19,26	21,50	22,04	/	/
VOL1832D4P	320	162	125	45	26	13	20,78	36	1:19,26	21,50	22,04	/	/
VOL1832C2	320	100	/	45	26	/	/	/	1:7,9	15,90	/	11,65	5
VOL1832C2P	320	162	125	45	26	/	/	/	1:7,9	20,53	/	14,30	5
VOL1835DAP	350	166	137	45	26	/	/	/	1:20	23,20	/	15,40	5

POMELLI/KNOB



ACC0018
Pomello in plastica.
Polypropylene knob **PP**



ACC2100
Pomello in poliuretano.
Polyurethane knob **PUR**



ACC2101
Pomello in poliuretano.
Polyurethane knob **PUR**



ACC1138
Pomello in poliuretano.
Polyurethane knob **PUR**

CLUSTER



J-CLUSTER

Combina le caratteristiche dei tradizionali indicatori a lancetta con le prestazioni e la flessibilità del display LCD TFT a colori ad alta risoluzione. Specificamente progettato per applicazioni in ambienti difficili, J-Cluster è lo strumento giusto per macchinari con e senza cabina.

Combines the features of traditional pointer indicators with the performance and flexibility of LCD TFT color high resolution display. Specifically designed for harsh environmental application, J-Cluster is the right instrument for machinery with and without cabin.



NIMBUS

Cluster in soluzione allo stato solido, con display 5" TFT a colori 800 cd (tecnologia IPS) e 7 indicatori a led. Microcontrollore potente e memoria di grandi dimensioni: 32bit, 8 Mb Flash e 8 Mb Ram.

Cluster in solid state solution, with display 5" TFT color 800 cd (IPS technology) and 7 led indicators. Powerfull microcontroller and large memory size: 32bit, 8 Mb Flash and 8 Mb Ram.



D100TFT

D100TFT è dotato di display da 2,4" TFT a colori ad alta luminosità in tecnologia IPS, linea canbus SAE J1939 e numerosi ingressi e uscite che consentono di gestire funzioni opzionali.

D100TFT is equipped with display 2,4" TFT color high-brightness in IPS technology, canbus line SAE J1939 and several inputs and outputs that allow to manage optional functions.

DISPLAY



SMARTVIEW

SMARTVIEW è uno strumento ultracompatto dotato di un display a colori TFT da 2,4", 5 indicatori a LED e 3 pulsanti. Adatto alle applicazioni in cui lo spazio è limitato, è in grado di gestire e visualizzare tutte le informazioni sulla macchina. In grado di collegarsi sia via CANBUS che con segnali "tradizionali", è il giusto compromesso tra economicità e alte prestazioni.

SMARTVIEW is an ultra-compact instrument equipped with a TFT color display 2,4", 5 LED indicators and 3 pushbuttons. Suitable for applications where space is limited, it is able to manage and display all the information on the machine. Able to connect both via CANBUS and with "traditional" signals, it is the right compromise between cost-effectiveness and high performance.



IMEL Division

Via Repubblica, 7 - 41011 Campogalliano, MO (Italy)
Tel. +39 0522 636911 - Fax. +39 0522 695753
www.ama.it - ama@ama.it

AMA S.p.A.
Accessori Macchine Agricole

Via Giacomo Puccini, 28 - 42018 San Martino in Rio (RE) Italy
Tel. +39 0522 636911 - Fax +39 0522 695753
www.ama.it - ama@ama.it